

VRUFM – Check valve DN 15:80

Check valve with BSP threaded female union ends.

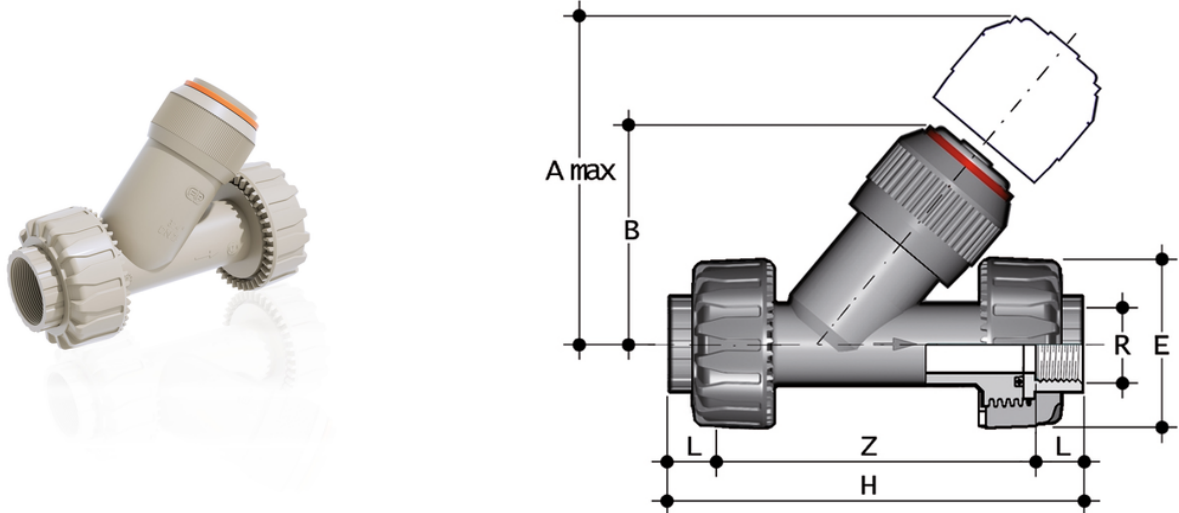

EPDM

| Reference | R | DN | PN | A max | B | E | H | Z | g |
|-----------|--------|----|----|-------|-----|-----|-----|-----|------|
| VRUFM012E | 1/2" | 15 | 10 | 125 | 71 | 55 | 143 | 113 | 165 |
| VRUFM034E | 3/4" | 20 | 10 | 145 | 83 | 65 | 160 | 127 | 227 |
| VRUFM100E | 1" | 25 | 10 | 165 | 94 | 74 | 183 | 145 | 380 |
| VRUFM114E | 1" 1/4 | 32 | 10 | 190 | 109 | 86 | 214 | 171 | 645 |
| VRUFM112E | 1" 1/2 | 40 | 10 | 210 | 119 | 99 | 235 | 192 | 915 |
| VRUFM200E | 2" | 50 | 10 | 240 | 143 | 120 | 285 | 234 | 1555 |

FKM

| Reference | R | DN | PN | A max | B | E | H | Z | g |
|-----------|--------|----|----|-------|-----|-----|-----|-----|------|
| VRUFM012F | 1/2" | 15 | 10 | 125 | 71 | 55 | 143 | 113 | 165 |
| VRUFM034F | 3/4" | 20 | 10 | 145 | 83 | 65 | 160 | 127 | 227 |
| VRUFM100F | 1" | 25 | 10 | 165 | 94 | 74 | 183 | 145 | 380 |
| VRUFM114F | 1" 1/4 | 32 | 10 | 190 | 109 | 86 | 214 | 171 | 645 |
| VRUFM112F | 1" 1/2 | 40 | 10 | 210 | 119 | 99 | 235 | 192 | 915 |
| VRUFM200F | 2" | 50 | 10 | 240 | 143 | 120 | 285 | 234 | 1555 |



VRUFM – Check valve DN 15:80

- Connection system for weld, threaded and flanged joints
- **No metal parts in contact with the fluid**
- **Piston with counterweight** able to work with high intensity fluid
- Limited pressure drop. Only minimum back pressure is required for the hermetic seal
- **Valve material compatibility** (PP-H) with water conveyance, drinking water and other food substances according to **current regulations**
- Can be maintained with the valve body installed