

DKOAM - DIALOCK® 2-way diaphragm valve DN 15:65

DIALOCK® diaphragm valve with flanged monolithic body, drilled ANSI B16.5 cl. 150 #FF.

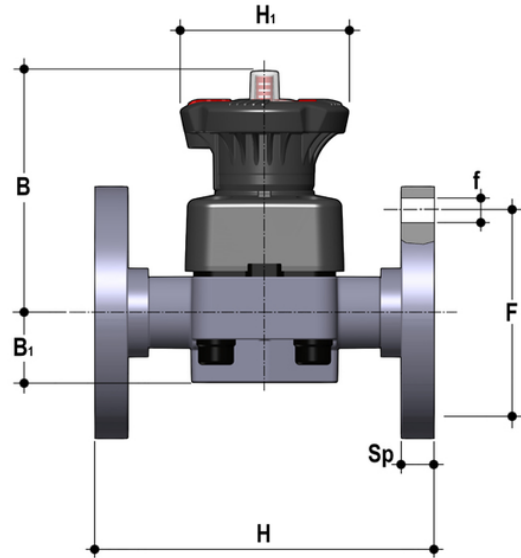

EPDM

Reference	d	DN	PN	B	B ₁	F	f	H	H ₁	Sp	U	g
DKOAM012E	1/2"	15	10	102	25	60.3	14	108	80	13,5	4	817
DKOAM034E	3/4"	20	10	105	30	70	15.7	120	80	13,5	4	850
DKOAM100E	1"	25	10	114	33	80	15.7	131	80	13,5	4	892
DKOAM114E	1" 1/4	32	10	119	30	89	15.7	162	80	14	4	1005
DKOAM112E	1" 1/2	40	10	149	35	99	15.7	180	120	16	4	1771
DKOAM200E	2"	50	10	172	46	121	19	210	120	16	4	2453
DKOAM212E	2" 1/2	65	10	172	46	140	19	250	120	21	4	2997

FKM

Reference	d	DN	PN	B	B ₁	F	f	H	H ₁	Sp	U	g
DKOAM012F	1/2"	15	10	102	25	60.3	14	108	80	13,5	4	817
DKOAM034F	3/4"	20	10	105	30	70	15.7	120	80	13,5	4	850
DKOAM100F	1"	25	10	114	33	80	15.7	131	80	13,5	4	892
DKOAM114F	1" 1/4	32	10	119	30	89	15.7	162	80	14	4	1005
DKOAM112F	1" 1/2	40	10	149	35	99	15.7	180	120	16	4	1771
DKOAM200F	2"	50	10	172	46	121	19	210	120	16	4	2453
DKOAM212F	2" 1/2	65	10	172	46	140	19	250	120	21	4	2997

DKOAM - DIALOCK® 2-way diaphragm valve DN 15:65

PTFE

Reference	d	DN	PN	B	B ₁	F	f	H	H ₁	Sp	U	g
DKOAM012P	1/2"	15	10	102	25	60.3	14	108	80	13,5	4	817
DKOAM034P	3/4"	20	10	105	30	70	15.7	120	80	13,5	4	850
DKOAM100P	1"	25	10	114	33	80	15.7	131	80	13,5	4	892
DKOAM114P	1" 1/4	32	10	119	30	89	15.7	162	80	14	4	1005
DKOAM112P	1" 1/2	40	10	149	35	99	15.7	180	120	16	4	1771
DKOAM200P	2"	50	10	172	46	121	19	210	120	16	4	2453
DKOAM212P	2" 1/2	65	10	172	46	140	19	250	120	21	4	2997

DKOAM – DIALOCK® 2-way diaphragm valve DN 15:65

- **High visibility graduated optical position indicator** protected by a transparent cap with seal O-Ring
- **Customisation plate:** the customisation lets you identify the valve on the system according to specific needs
- **DIALOCK® SYSTEM:** innovative handwheel with a patented immediate and ergonomic operating locking device that allows it **to be adjusted and locked in over 300 positions**
- **Handwheel and bonnet in** high mechanical strength and chemically resistant **PP-GR**, providing full protection by isolating all internal metal parts from contact with external agents
- **Floating pin connection** between the control screw and diaphragm to prevent concentrated loads, improve the seal and extend its lifetime
- **New design of valve body interior: substantially increased flow coefficient** and reduced pressure drop. The degree of efficiency reached has also **enabled the size and weight of the valve to be reduced**
- **Adjustment linearity:** the internal profiles of the valve also greatly improve its characteristic curve, resulting in **extremely sensitive and precise adjustment** along the entire stroke of the shutter
- **Valve anchoring** bracket **integrated in the body**, with threaded metal inserts allowing **simple panel or wall mounting** using the PMDK mounting plate (supplied as an accessory)

- Connection system for solvent weld, threaded and flanged joints
- **Optimised fluid dynamic design:** maximum output flow rate thanks to the optimised efficiency of the fluid dynamics that characterise the new internal geometry of the body
- **Internal components in metal, totally isolated from the fluid** and external environment
- **Modularity of the range:** only 2 handwheel and 4 diaphragm and bonnet sizes for 7 different valve sizes
- Non-rising handwheel that stays at the same height during rotation, equipped with a graduated optical indicator protected by a transparent PVC cap with seal O-Ring
- Bonnet fastening screws in stainless steel protected against the external environment by PE plugs. Absence of metal parts exposed to the external environment to prevent any risk of corrosion
- **CDSA** (Circular Diaphragm Sealing Angle) system that, thanks to the uniform distribution of shutter pressure on the diaphragm seal, offers the following advantages:
 - reduction in the tightening torque of the screws fixing the actuator to the valve body
 - reduced mechanical stress on all valve components (actuator, body and diaphragm)
 - easy to clean valve interior
 - low risk of the accumulation of deposits, contamination or damage to the diaphragm due to crystallisation
 - operating torque reduction