

VXEBEV - Easyfit 2-way ball valve DN 65:100

Easyfit 2-way ball valve with PE100 SDR 11 male connectors for butt welding or electrofusion (CVDE).

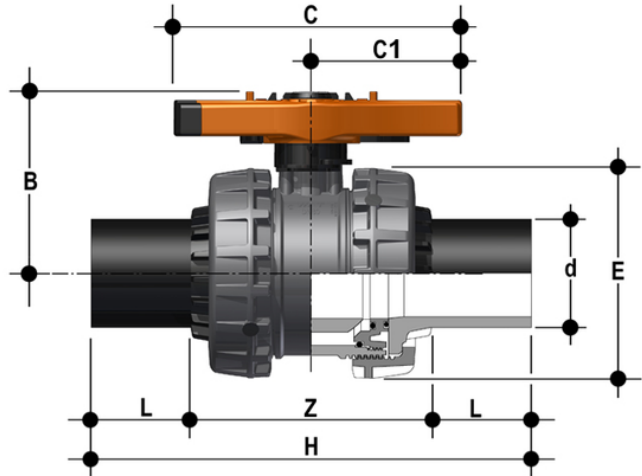

EPDM

Reference	d	DN	PN	B	C	C ₁	E	H	L	Z	g
VXEBEV075E	75	65	16	141,5	214	115	157	331	71	189	2286
VXEBEV090E	90	80	10	151	239	126	174	367	88	191	3059
VXEBEV110E	110	100	10	174,5	270	145	212	407	92	223	5814

FKM

Reference	d	DN	PN	B	C	C ₁	E	H	L	Z	g
VXEBEV075F	75	65	16	141,5	214	115	157	331	71	189	2286
VXEBEV090F	90	80	10	151	239	126	174	367	88	191	3059
VXEBEV110F	110	100	10	174,5	270	145	212	407	92	223	5814

PE

Reference	d	DN	PN	B	C	C ₁	E	H	L	Z	g
VXEBEV075M	75	65	16	141,5	214	115	157	331	71	189	2286
VXEBEV090M	90	80	10	151	239	126	174	367	88	191	3059
VXEBEV110M	110	100	10	174,5	270	145	212	407	92	223	5814

VXEBEV – Easyfit 2-way ball valve

DN 65:100

- **Innovative Easyfit quick release handle** made up of a central hub firmly coupled with the stem valve and **dual spoke grip** that can be released from the hub with a simple operation and used as a **ball seat adjustment tool** and as a **union nut tightening tool** thanks to the hooked insert that, perfectly adapting to their external profile, allows the handle to transform into a wrench to control union nut rotation
- **Customisable Labelling System: built-in LCE module** in the hub made up of transparent protection plug and customisable tag holder using the LSE set (available as accessory). The customisation potential lets you **identify the valve on the system** according to specific needs
- **PTFE ball seat system with locked carrier** adjustable via the Easyfit quick release handle
- **Stem** with high surface finish and **double O-Ring** and **PTFE antifriction disk** that limits friction to a minimum and grants excellent operating torque
- **Locking device** in closing and opening via lock
- Machined high surface finish ball that guarantees a smooth operation and increased reliability

- **Patented Easyfit system:** innovative mechanism based on the multifunctional handle quick release mechanism that permits union nut rotation during valve installation and ball carrier adjustment
- Connection system for solvent weld and threaded joints
- **Valve material compatibility** (PVC-U) and elastomer **seal elements** (EPDM or FKM), with water, drinking water and other food substances as per **current regulations**
- Easy radial dismounting allowing quick replacement of O-rings and ball seats without any need for tools
- **PN16 True Union valve body** made for PVC-U injection moulding and European Directive 2014/68/EU (PED) compliant for pressurised equipment. ISO 9393 compliant test requirements
- Valve body with built in anchoring frame for the special **Power Quick module** dedicated to accessory or pneumatic and electric actuator installation
- Option of dismounting downstream pipes with the valve in the closed position
- Floating **full bore ball** with high surface finish made in CNC work stations to achieve precise dimensional tolerance and high surface finish