

VXEGV - Easyfit 2-way ball valve 65:100

Easyfit 2-way ball valve with female ends, JIS thread.

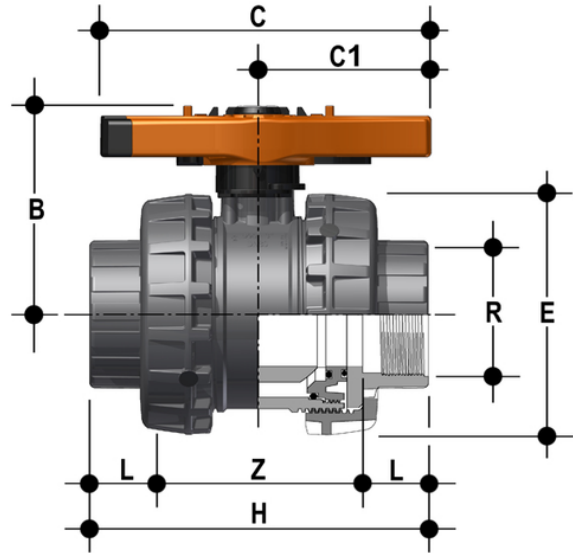

EPDM

Reference	R	DN	PN	B	C	C ₁	E	H	L	Z	g
VXEGV212E	2"1/2	65	16	142	214	115	157	211	35	141	2750
VXEGV300E	3"	80	16	151	239	126	174	248	40	168	3432
VXEGV400E	4"	100	16	174,5	270	145	212	283	45	193	5814

FKM

Reference	R	DN	PN	B	C	C ₁	E	H	L	Z	g
VXEGV212F	2"1/2	65	16	142	214	115	157	211	35	141	2750
VXEGV300F	3"	80	16	151	239	126	174	248	40	168	3432
VXEGV400F	4"	100	16	174,5	270	145	212	283	45	193	5814

PE

Reference	R	DN	PN	B	C	C ₁	E	H	L	Z	g
VXEGV212M	2"1/2	65	16	142	214	115	157	211	35	141	2750
VXEGV300M	3"	80	16	151	239	126	174	248	40	168	3432
VXEGV400M	4"	100	16	174,5	270	145	212	283	45	193	5814

VXEGV – Easyfit 2-way ball valve 65:100

- **Innovative Easyfit quick release handle** made up of a central hub firmly coupled with the stem valve and **dual spoke grip** that can be released from the hub with a simple operation and used as a **ball seat adjustment tool** and as a **union nut tightening tool** thanks to the hooked insert that, perfectly adapting to their external profile, allows the handle to transform into a wrench to control union nut rotation
- **Customisable Labelling System: built-in LCE module** in the hub made up of transparent protection plug and customisable tag holder using the LSE set (available as accessory). The customisation potential lets you **identify the valve on the system** according to specific needs
- **PTFE ball seat system with locked carrier** adjustable via the Easyfit quick release handle
- **Stem** with high surface finish and **double O-Ring** and **PTFE antifriction disk** that limits friction to a minimum and grants excellent operating torque
- **Locking device** in closing and opening via lock
- Machined high surface finish ball that guarantees a smooth operation and increased reliability
- **Patented Easyfit system:** innovative mechanism based on the multifunctional handle quick release mechanism that permits union nut rotation during valve installation and ball carrier adjustment
- Connection system for solvent weld and threaded joints
- **Valve material compatibility** (PVC-U) and elastomer **seal elements** (EPDM or FKM), with water, drinking water and other food substances as per **current regulations**
- Easy radial dismounting allowing quick replacement of O-rings and ball seats without any need for tools
- **PN16 True Union valve body** made for PVC-U injection moulding and European Directive 2014/68/EU (PED) compliant for pressurised equipment. ISO 9393 compliant test requirements
- Valve body with built in anchoring frame for the special **Power Quick module** dedicated to accessory or pneumatic and electric actuator installation
- Option of dismounting downstream pipes with the valve in the closed position
- Floating **full bore ball** with high surface finish made in CNC work stations to achieve precise dimensional tolerance and high surface finish