

VKDOV - VKDOAV DUAL BLOCK®

2-way ball valve DN 65:100

VKDOV: DUAL BLOCK® 2-way ball valve with fixed flanges, drilled PN10/16. Face to face according to EN 558-1

VKDOAV: DUAL BLOCK® 2-way ball valve with fixed flanges, drilled ANSI B.16.5 cl.150 #FF. Face to face according to EN 558-1

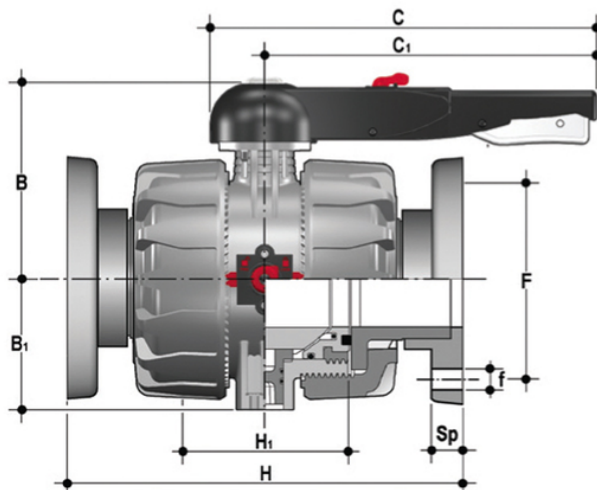

EPDM

Reference	d	DN	PN	B	B ₁	C	C[5:1]	F	f	H	H ₁	Sp	U	g
VKDOV075E	75	65	16	164	87	327	175	145	17	290	133	21	4	6610
VKDOV090E	90	80	16	177	105	327	272	160	17	310	149	21,5	8	9330
VKDOV110E	110	100	16	195	129	385	330	180	17	350	167	21,5	8	13815

FKM

Reference	d	DN	PN	B	B ₁	C	C[5:1]	F	f	H	H ₁	Sp	U	g
VKDOV075F	75	65	16	164	87	327	175	145	17	290	133	21	4	6610
VKDOV090F	90	80	16	177	105	327	272	160	17	310	149	21,5	8	9330
VKDOV110F	110	100	16	195	129	385	330	180	17	350	167	21,5	8	13815

VKDOV – VKDOAV DUAL BLOCK®

2-way ball valve DN 65:100

- HIPVC ergonomic multifunctional handle for quick operation, **lock and graduated adjustment in 10 positions**. Possibility of inhibiting rotation with a lock
- Customisable Labelling System: LCE module made of a transparent protection plug and **customisable tag holder** using the LSE set (available as accessory). The customisation lets you identify the valve on the system according to specific needs
- **DUAL BLOCK®** patented lock system that ensures union nut tightening hold even in severe conditions such as vibrations or heat dilation
- **Double stem** with double O-Rings for ball centring and operating torque reduction
- Machined high surface finish ball that guarantees a smooth operation and increased reliability

- Connection system for solvent weld, threaded and flanged joints
- Patented **SEAT STOP®** ball carrier system that lets you micro-adjust seals and minimise axial force effects
- Easy radial dismounting allowing quick replacement of O-rings and ball seats without any need for tools
- **PN16 True Union valve body** made for rigid PVC-U injection moulding equipped with built-in bores for actuation. ISO 9393 compliant test requisites
- Option of dismounting downstream pipes with the valve in the closed position
- **Full bore ball** with high surface finish
- **Integrated bracket** for valve anchoring
- Possibility of installing a manual reducer or pneumatic and/or electric actuators by applying an ISO standard bore PP-GR flange
- **STAINLESS steel co-moulded stem**, with square section as per ISO 5211
- Possibility to have handle with integrated LSQT limit micro switch, even as a retrofit in existing installations