

# VKROV - DUAL BLOCK® regulating ball valve DN 10:50

DUAL BLOCK® regulating ball valve with EN/ISO/DIN fixed flange, drilled PN10/16. Face to face according to EN 558-1.

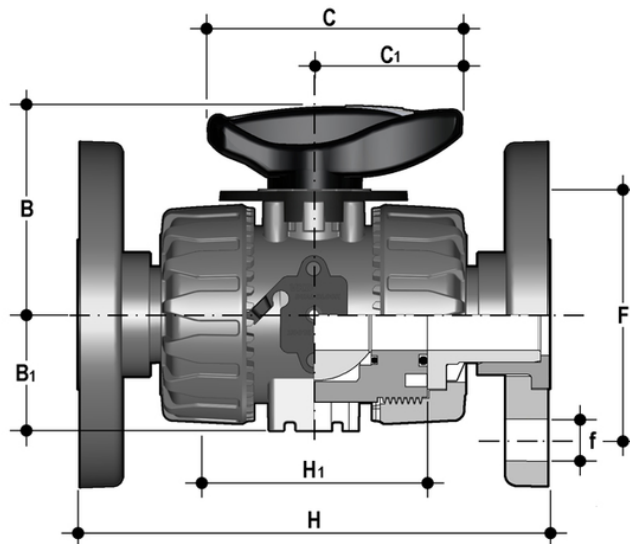

### EPDM

Reference	d	DN	PN	B	B <sub>1</sub>	C	C <sub>1</sub>	F	H	H <sub>1</sub>	U	f	Sp	g
VKROV020E	20	15	16	54	29	67	40	65	130	65	4	14	11	375
VKROV025E	25	20	16	65	34,5	85	49	75	150	70	4	14	14	590
VKROV032E	32	25	16	69,5	39	85	49	85	160	78	4	14	14	713
VKROV040E	40	32	16	82,5	46	108	64	100	180	88	4	18	14	1108
VKROV050E	50	40	16	89	52	108	64	110	200	93	4	18	16	1485
VKROV063E	63	50	16	108	62	134	76	125	230	111	4	18	16	2347

### FKM

Reference	d	DN	PN	B	B <sub>1</sub>	C	C <sub>1</sub>	F	H	H <sub>1</sub>	U	f	Sp	g
VKROV020F	20	15	16	54	29	67	40	65	130	65	4	14	11	375
VKROV025F	25	20	16	65	34,5	85	49	75	150	70	4	14	14	590
VKROV032F	32	25	16	69,5	39	85	49	85	160	78	4	14	14	713
VKROV040F	40	32	16	82,5	46	108	64	100	180	88	4	18	14	1108
VKROV050F	50	40	16	89	52	108	64	110	200	93	4	18	16	1485
VKROV063F	63	50	16	108	62	134	76	125	230	111	4	18	16	2347

# VKROV – DUAL BLOCK®

## regulating ball valve DN 10:50

- HIPVC ergonomic multifunctional handle with **position indicator** and tool to adjust the ball seat carrier
- Flow direction and opening angle indication plate with **graduated scale with 5° detail** for clear and accurate readings
- 90° operating angle that permits **the use of standard** quarter turn **actuators**
- The patented ball design provides **linear flow adjustment** throughout its range of operation even when the valve is open just a few degrees and guarantees minimum pressure drops
- Patented **DUAL BLOCK®** system: prevents union nuts from loosening even under extreme operating conditions: e.g. vibration or thermal expansion
  
- Connection system for solvent weld, threaded and flanged joints
- Patented **SEAT STOP®** ball carrier system that lets you micro-adjust seals and minimise the axial force effect
- Easy radial dismounting allowing quick replacement of O-rings and ball seats without any need for tools
- **PN16 True Union valve body** made for rigid PVC-U injection moulding equipped with built-in bores for actuation. ISO 9393 compliant test requisites
- Option of dismounting downstream pipes with the valve in the closed position
- High surface finish stem with double O-Ring and double connection key to ball
- **Integrated bracket** for valve anchoring
- Ball seat carrier can be adjusted using the **Easytorque adjustment kit**
- Actuation option: version with electric modulating actuator with 4-20 mA / 0-10 V inlet and 4-20 mA / 0-10 V outlet to monitor the position
- Valve suitable for carrying fluids that are clean and free of suspended particles