

# VKDAC - DUAL BLOCK® 2-way ball valve DN 10:50

DUAL BLOCK® 2-way ball valve with female ends for solvent welding, ASTM series.

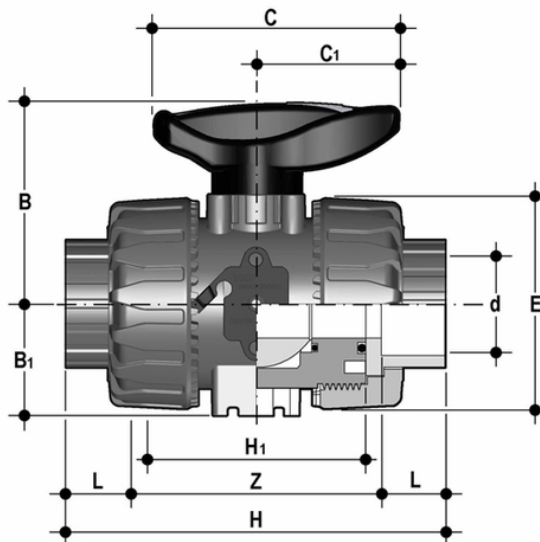

## EPDM

Reference	d	DN	PN	B	B <sub>1</sub>	C	C[5:1]	E	H	H <sub>1</sub>	L	Z	g
VKDAC012E	1/2"	15	16	54	29	67	40	54	117	65	22,5	72	234
VKDAC034E	3/4"	20	16	65	34,5	85	49	65	129	70	25,5	78	375
VKDAC100E	1"	25	16	69,5	39	85	49	73	142	78	28,7	84,6	487
VKDAC114E	1" 1/4	32	16	82,5	46	108	64	86	162	88	32	98	780
VKDAC112E	1" 1/2	40	16	89	52	108	64	98	172	93	35	102	1062
VKDAC200E	2"	50	16	108	62	134	76	122	199	111	38,2	122,6	1864

## FKM

Reference	d	DN	PN	B	B <sub>1</sub>	C	C[5:1]	E	H	H <sub>1</sub>	L	Z	g
VKDAC012F	1/2"	15	16	54	29	67	40	54	117	65	22,5	72	237
VKDAC034F	3/4"	20	16	65	34,5	85	49	65	129	70	25,5	78	375
VKDAC100F	1"	25	16	69,5	39	85	49	73	142	78	28,7	84,6	487
VKDAC114F	1" 1/4	32	16	82,5	46	108	64	86	162	88	32	98	780
VKDAC112F	1" 1/2	40	16	89	52	108	64	98	172	93	35	102	1062
VKDAC200F	2"	50	16	108	62	134	76	122	199	111	38,2	122,6	1864

# VKDAC - DUAL BLOCK® 2-way ball valve DN 10:50

- Ergonomic HIPVC handle equipped with **removable tool to adjust the ball seat carrier**.
- **Handle lock 0°- 90° SHKD** (available as an accessory) ergonomically operable during service and padlockable
- Robust **integrated bracket for valve anchoring**, for easy and quick automation even after valve installation on the system via the Power Quick module (optional)
- **DUAL BLOCK®** patented lock system that ensures union nut tightening hold even in severe conditions such as vibrations or heat dilation
- Machined high surface finish ball that guarantees a smooth operation and increased reliability
  
- Connection system for solvent weld, threaded and flanged joints
- Patented **SEAT STOP®** ball carrier system that lets you micro-adjust ball seats and minimise the axial force effect
- Easy radial dismounting allowing quick replacement of O-rings and ball seats without any need for tools
- **PN16 True Union valve body** made for rigid PVC-U injection moulding equipped with built-in bores for actuation. ISO 9393 compliant test requisites
- Option of dismounting downstream pipes with the valve in the closed position
- Floating **full bore ball** with high surface finish
- **Integrated bracket** for valve anchoring
- Ball seat carriers can be adjusted using the **Easytorque adjustment kit**
- Possibility to have handle with integrated LSQT limit micro switch, even as a retrofit in existing installations