

VKDDM - DUAL BLOCK® 2-way ball valve 65:100

DUAL BLOCK® 2-way ball valve with male ends for socket welding, metric series.

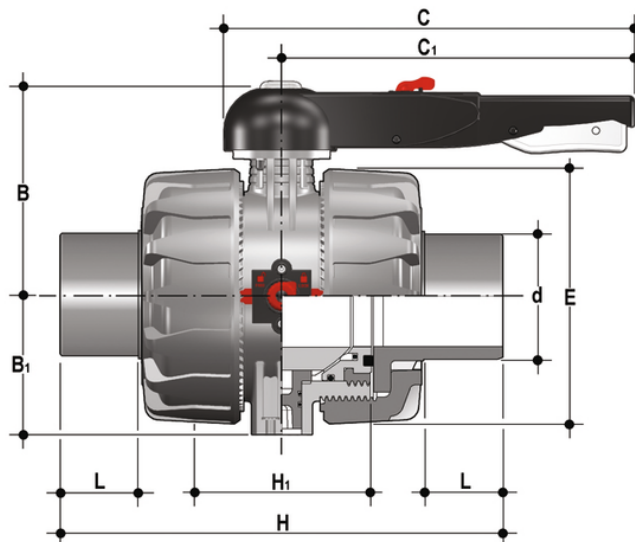

EPDM

Reference	d	DN	PN	B	B ₁	C	C ₁	E	H	H ₁	L	g
VKDDM075E	75	65	10	164	87	225	175	162	284	133	44	3190
VKDDM090E	90	80	10	177	105	327	272	202	300	149	51	5280
VKDDM110E	110	100	10	195	129	385	330	236	340	167	61	8010

FKM

Reference	d	DN	PN	B	B ₁	C	C ₁	E	H	H ₁	L	g
VKDDM075F	75	65	10	164	87	225	175	162	284	133	44	3190
VKDDM090F	90	80	10	177	105	327	272	202	300	149	51	5280
VKDDM110F	110	100	10	195	129	385	330	236	340	167	61	8010

VKDDM - DUAL BLOCK® 2-way ball valve 65:100

- HIPVC ergonomic multifunctional handle for quick operation, **lock and graduated adjustment in 10 positions**. Possibility of inhibiting rotation with a lock
- Customisable Labelling System: LCE module made of a transparent protection plug and **customisable tag holder** using the LSE set (available as accessory). The customisation lets you identify the valve on the system according to specific needs
- **DUAL BLOCK®** patented lock system that ensures union nut tightening hold even in severe conditions such as vibrations or heat dilation
- **Double stem** with double O-Rings for ball centring and operating torque reduction
- Machined high surface finish ball that guarantees a smooth operation and increased reliability

- Connection system for solvent weld, threaded and flanged joints
- Patented **SEAT STOP®** ball carrier system that lets you micro-adjust seals and minimise axial force effects
- Easy radial dismounting allowing quick replacement of O-rings and ball seats without any need for tools
- **PN16 True Union valve body** made for rigid PVC-U injection moulding equipped with built-in bores for actuation. ISO 9393 compliant test requisites
- Option of dismounting downstream pipes with the valve in the closed position
- **Full bore ball** with high surface finish
- **Integrated bracket** for valve anchoring
- Possibility of installing a manual reducer or pneumatic and/or electric actuators by applying an ISO standard bore PP-GR flange
- **STAINLESS steel co-moulded stem**, with square section as per ISO 5211
- Possibility to have handle with integrated LSQT limit micro switch, even as a retrofit in existing installations