

VKDGV - DUAL BLOCK® 2-way ball valve

DUAL BLOCK® 2-way ball valve with female ends, JIS thread.

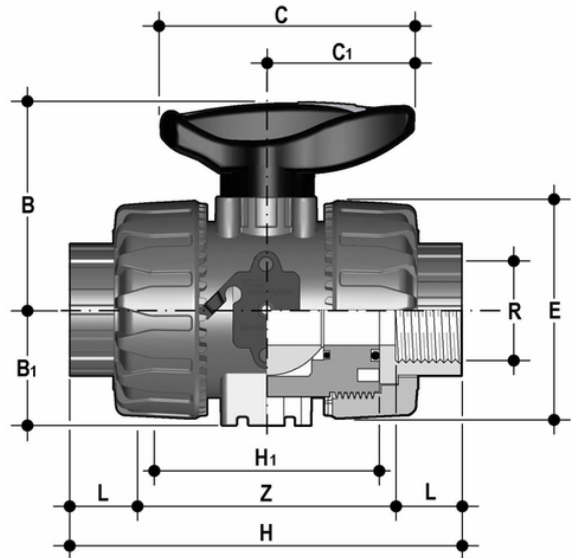

EPDM

Reference	R	DN	PN	B	B ₁	C	C ₁	E	H	H ₁	L	Z	g
VKDGV012E	1/2"	15	16	54	29	67	40	54	103	65	16	71	210
VKDGV034E	3/4"	20	16	65	34,5	85	49	65	115	70	19	77	330
VKDGV100E	1"	25	16	69,5	39	85	49	73	128	78	22	84	438
VKDGV114E	1" 1/4	32	16	82,5	46	108	64	86	146	88	25	96	678
VKDGV112E	1" 1/2	40	16	89	52	108	64	98	164	93	26	112	975
VKDGV200E	2"	50	16	108	62	134	76	122	199	111	31	137	1627

FKM

Reference	R	DN	PN	B	B ₁	C	C ₁	E	H	H ₁	L	Z	g
VKDGV012F	1/2"	15	16	54	29	67	40	54	103	65	16	71	210
VKDGV034F	3/4"	20	16	65	34,5	85	49	65	115	70	19	77	330
VKDGV100F	1"	25	16	69,5	39	85	49	73	128	78	22	84	438
VKDGV114F	1" 1/4	32	16	82,5	46	108	64	86	146	88	25	96	678
VKDGV112F	1" 1/2	40	16	89	52	108	64	98	164	93	26	112	975
VKDGV200F	2"	50	16	108	62	134	76	122	199	111	31	137	1627

VKDGV – DUAL BLOCK® 2-way ball valve

- Ergonomic HIPVC handle equipped with **removable tool to adjust the ball seat carrier**.
- **Handle lock 0°– 90° SHKD** (available as an accessory) ergonomically operable during service and padlockable
- Robust **integrated bracket for valve anchoring**, for easy and quick automation even after valve installation on the system via the Power Quick module (optional)
- **DUAL BLOCK®** patented lock system that ensures union nut tightening hold even in severe conditions such as vibrations or heat dilation
- Machined high surface finish ball that guarantees a smooth operation and increased reliability

- Connection system for solvent weld, threaded and flanged joints
- Patented **SEAT STOP®** ball carrier system that lets you micro-adjust ball seats and minimise the axial force effect
- Easy radial dismounting allowing quick replacement of O-rings and ball seats without any need for tools
- **PN16 True Union valve body** made for rigid PVC-U injection moulding equipped with built-in bores for actuation. ISO 9393 compliant test requisites
- Option of dismounting downstream pipes with the valve in the closed position
- Floating **full bore ball** with high surface finish
- **Integrated bracket** for valve anchoring
- Ball seat carriers can be adjusted using the **Easytorque adjustment kit**
- Possibility to have handle with integrated LSQT limit micro switch, even as a retrofit in existing installations