

# LKDAV - DUAL BLOCK® 3-way ball valve DN 10:50

DUAL BLOCK® 3-way ball valve with female ends for solvent welding, ASTM series, L-port ball.

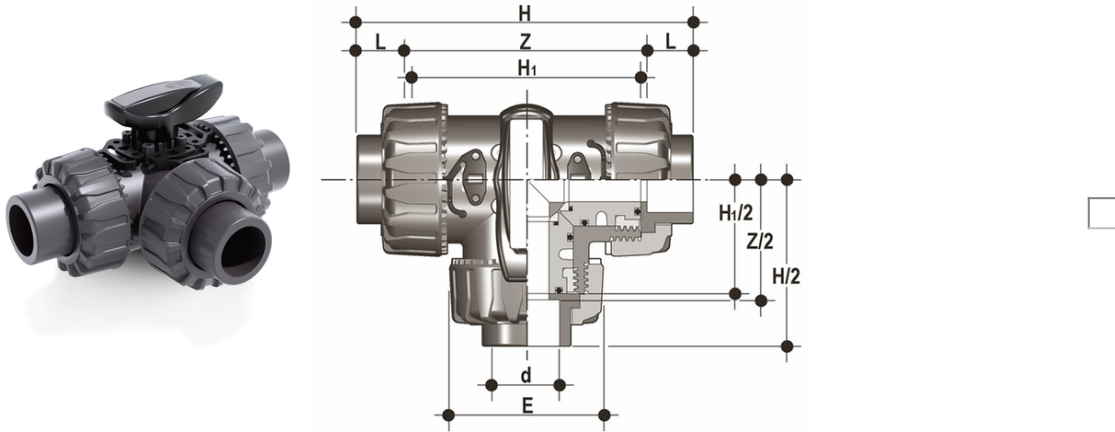

## EPDM

Reference	d	DN	PN	E	H	H <sub>1</sub>	L	Z	g
LKDAV038E	3/8"	10	16	54	132,2	80	19.5	93.2	310
LKDAV012E	1/2"	15	16	54	132,2	80	23	87,2	310
LKDAV034E	3/4"	20	16	65	159,2	100	25.5	108.2	550
LKDAV100E	1"	25	16	73	174	110	28.7	116.6	790
LKDAV114E	1" 1/4	32	16	86	205	131	32	141	1275
LKDAV112E	1" 1/2	40	16	98	227.6	148	35	157.6	1660
LKDAV200E	2"	50	16	122	267	179	38,2	190.6	2800

## FKM

Reference	d	DN	PN	E	H	H <sub>1</sub>	L	Z	g
LKDAV038F	3/8"	10	16	54	132,2	80	19.5	93.2	310
LKDAV012F	1/2"	15	16	54	132,2	80	23	87,2	310
LKDAV034F	3/4"	20	16	65	159,2	100	25.5	108.2	550
LKDAV100F	1"	25	16	73	174	110	28.7	116.6	790
LKDAV114F	1" 1/4	32	16	86	205	131	32	141	1275
LKDAV112F	1" 1/2	40	16	98	227.6	148	35	157.6	1660
LKDAV200F	2"	50	16	122	267	179	38,2	190.6	2800

# LKDAV – DUAL BLOCK® 3-way ball valve DN 10:50

- Ergonomic HIPVC handle equipped with removable tool to adjust the ball seat carrier. Possibility of installing the **LTKD stroke limiter** (available as an accessory) that permits ball and handle rotation only for set opening and closing angles at 90° or 180°
- **Handle lock 0°– 90° SHKD** (available as an accessory) ergonomically operable during service and padlockable
- **DUAL BLOCK®** patented lock system that ensures union nut tightening hold even in severe conditions such as vibrations or heat dilation
- **Ball shutter** high surface finish with floating type full passage with **T or L port**
- **4 PTFE ball seat system** that compensates axial force guaranteeing optimal manageability and long working life
  
- Connection system for solvent weld, threaded and flanged joints
- Patented **SEAT STOP®** ball carrier system that lets you micro-adjust ball seats and minimise axial force effects
- Easy radial dismounting allowing quick replacement of O-rings and ball seats without any need for tools
- **PN16 True Union valve body** made for rigid PVC-U injection moulding equipped with built-in bores for actuation. ISO 9393 compliant test requisites
- Option of dismounting downstream pipes with the valve in the closed position
- High surface finish stem with double O-Ring and double connection key to the ball, equipped with **visual ball position indicator** for correct handle installation
- **Integrated bracket** for valve anchoring
- Possibility of installing pneumatic and/or electric actuators thanks to the robust anchor tower for easy and quick automation using the **Power Quick module** (optional)
- Possibility to have handle with integrated LSQT limit micro switch, even as a retrofit in existing installations