

VKRLV - DUAL BLOCK® regulating ball valve DN 10:50

DUAL BLOCK® regulating ball valve with BS plain socket ends for solvent welding.

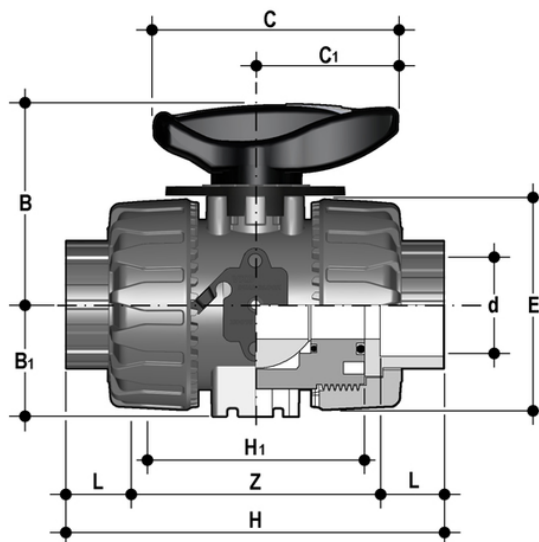

EPDM

Reference	d	DN	PN	B	B ₁	C	C ₁	E	H	H ₁	L	Z	g
VKRLV038E	3/8"	10	16	54	29	67	40	54	103	65	14,5	74	210
VKRLV012E	1/2"	15	16	54	29	67	40	54	103	65	16,5	70	205
VKRLV034E	3/4"	20	16	65	34,5	85	49	65	115	70	19	77	335
VKRLV100E	1"	25	16	69,5	39	85	49	73	128	78	22,5	83	433
VKRLV114E	1" 1/4	32	16	82,5	46	108	64	86	146	88	26	94	703
VKRLV112E	1" 1/2	40	16	89	52	108	64	98	164	93	30	104	925
VKRLV200E	2"	50	16	108	62	134	76	122	199	111	36	127	1647

FKM

Reference	d	DN	PN	B	B ₁	C	C ₁	E	H	H ₁	L	Z	g
VKRLV038F	3/8"	10	16	54	29	67	40	54	103	65	14,5	74	210
VKRLV012F	1/2"	15	16	54	29	67	40	54	103	65	16,5	70	205
VKRLV034F	3/4"	20	16	65	34,5	85	49	65	115	70	19	77	335
VKRLV100F	1"	25	16	69,5	39	85	49	73	128	78	22,5	83	433
VKRLV114F	1" 1/4	32	16	82,5	46	108	64	86	146	88	26	94	703
VKRLV112F	1" 1/2	40	16	89	52	108	64	98	164	93	30	104	925
VKRLV200F	2"	50	16	108	62	134	76	122	199	111	36	127	1647

VKRLV – DUAL BLOCK® regulating ball valve DN 10:50

- HIPVC ergonomic multifunctional handle with **position indicator** and tool to adjust the ball seat carrier
- Flow direction and opening angle indication plate with **graduated scale with 5° detail** for clear and accurate readings
- 90° operating angle that permits **the use of standard** quarter turn **actuators**
- The patented ball design provides **linear flow adjustment** throughout its range of operation even when the valve is open just a few degrees and guarantees minimum pressure drops
- Patented **DUAL BLOCK®** system: prevents union nuts from loosening even under extreme operating conditions: e.g. vibration or thermal expansion

- Connection system for solvent weld, threaded and flanged joints
- Patented **SEAT STOP®** ball carrier system that lets you micro-adjust seals and minimise the axial force effect
- Easy radial dismounting allowing quick replacement of O-rings and ball seats without any need for tools
- **PN16 True Union valve body** made for rigid PVC-U injection moulding equipped with built-in bores for actuation. ISO 9393 compliant test requisites
- Option of dismounting downstream pipes with the valve in the closed position
- High surface finish stem with double O-Ring and double connection key to ball
- **Integrated bracket** for valve anchoring
- Ball seat carrier can be adjusted using the **Easytorque adjustment kit**
- Actuation option: version with electric modulating actuator with 4-20 mA / 0-10 V inlet and 4-20 mA / 0-10 V outlet to monitor the position
- Valve suitable for carrying fluids that are clean and free of suspended particles