

VKRDV - DUAL BLOCK® regulating ball valve DN 10:50

DUAL BLOCK® regulating ball valve with male ends for solvent welding, metric series.

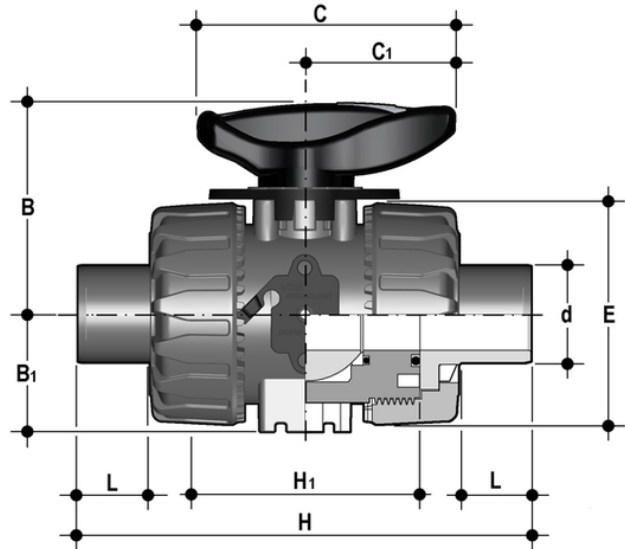

EPDM

Reference	d	DN	PN	B	B ₁	C	C[5:1]	E	H	H ₁	L	g
VKRDV016E	16	10	16	54	29	67	40	54	149	65	14	215
VKRDV020E	20	15	16	54	29	67	40	54	124	65	16	220
VKRDV025E	25	20	16	65	34,5	85	49	65	144	70	19	340
VKRDV032E	32	25	16	69,5	39	85	49	73	154	78	22	443
VKRDV040E	40	32	16	82,5	46	108	64	86	174	88	26	693
VKRDV050E	50	40	16	89	52	108	64	98	194	93	31	945
VKRDV063E	63	50	16	108	62	134	76	122	224	111	38	1607

FKM

Reference	d	DN	PN	B	B ₁	C	C[5:1]	E	H	H ₁	L	g
VKRDV016F	16	10	16	54	29	67	40	54	149	65	14	215
VKRDV020F	20	15	16	54	29	67	40	54	124	65	16	220
VKRDV025F	25	20	16	65	34,5	85	49	65	144	70	19	340
VKRDV032F	32	25	16	69,5	39	85	49	73	154	78	22	443
VKRDV040F	40	32	16	82,5	46	108	64	86	174	88	26	693
VKRDV050F	50	40	16	89	52	108	64	98	194	93	31	945
VKRDV063F	63	50	16	108	62	134	76	122	224	111	38	1607

VKRDV – DUAL BLOCK® regulating ball valve DN 10:50

- HIPVC ergonomic multifunctional handle with **position indicator** and tool to adjust the ball seat carrier
- Flow direction and opening angle indication plate with **graduated scale with 5° detail** for clear and accurate readings
- 90° operating angle that permits **the use of standard** quarter turn **actuators**
- The patented ball design provides **linear flow adjustment** throughout its range of operation even when the valve is open just a few degrees and guarantees minimum pressure drops
- Patented **DUAL BLOCK®** system: prevents union nuts from loosening even under extreme operating conditions: e.g. vibration or thermal expansion

- Connection system for solvent weld, threaded and flanged joints
- Patented **SEAT STOP®** ball carrier system that lets you micro-adjust seals and minimise the axial force effect
- Easy radial dismounting allowing quick replacement of O-rings and ball seats without any need for tools
- **PN16 True Union valve body** made for rigid PVC-U injection moulding equipped with built-in bores for actuation. ISO 9393 compliant test requisites
- Option of dismounting downstream pipes with the valve in the closed position
- High surface finish stem with double O-Ring and double connection key to ball
- **Integrated bracket** for valve anchoring
- Ball seat carrier can be adjusted using the **Easytorque adjustment kit**
- Actuation option: version with electric modulating actuator with 4-20 mA / 0-10 V inlet and 4-20 mA / 0-10 V outlet to monitor the position
- Valve suitable for carrying fluids that are clean and free of suspended particles