

TKDLV - DUAL BLOCK® 3-way ball valve

DUAL BLOCK® 3-way ball valve with BS plain socket ends for solvent welding, T bore.

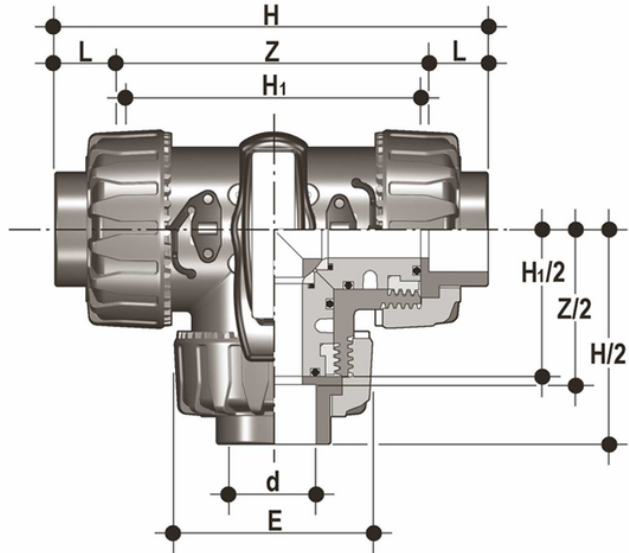

EPDM

Reference	d	DN	PN	E	H	H ₁	L	Z	g
TKDLV038E	3/8"	10	16	54	118	80	14.7	88.6	310
TKDLV012E	1/2"	15	16	54	118	80	17	85	310
TKDLV034E	3/4"	20	16	65	144.8	100	19	106.8	550
TKDLV100E	1"	25	16	73	160	110	22.5	115	790
TKDLV114E	1" 1/4	32	16	86	188.6	131	26	136.6	1275
TKDLV112E	1" 1/2	40	16	98	219.4	148	30.2	159	1660
TKDLV200E	2"	50	16	122	266.6	179	36.2	194.2	2800

FKM

Reference	d	DN	PN	E	H	H ₁	L	Z	g
TKDLV038F	3/8"	10	16	54	118	80	14.7	88.6	310
TKDLV012F	1/2"	15	16	54	118	80	17	85	310
TKDLV034F	3/4"	20	16	65	144.8	100	19	106.8	550
TKDLV100F	1"	25	16	73	160	110	22.5	115	790
TKDLV114F	1" 1/4	32	16	86	188.6	131	26	136.6	1275
TKDLV112F	1" 1/2	40	16	98	219.4	148	30.2	159	1660
TKDLV200F	2"	50	16	122	266.6	179	36.2	194.2	2800

TKDLV – DUAL BLOCK® 3-way ball valve

- Ergonomic HIPVC handle equipped with removable tool to adjust the ball seat carrier. Possibility of installing the **LTKD stroke limiter** (available as an accessory) that permits ball and handle rotation only for set opening and closing angles at 90° or 180°
- **Handle lock 0°– 90° SHKD** (available as an accessory) ergonomically operable during service and padlockable
- **DUAL BLOCK®** patented lock system that ensures union nut tightening hold even in severe conditions such as vibrations or heat dilation
- **Ball shutter** high surface finish with floating type full passage with **T or L port**
- **4 PTFE ball seat system** that compensates axial force guaranteeing optimal manageability and long working life

- Connection system for solvent weld, threaded and flanged joints
- Patented **SEAT STOP®** ball carrier system that lets you micro-adjust ball seats and minimise axial force effects
- Easy radial dismounting allowing quick replacement of O-rings and ball seats without any need for tools
- **PN16 True Union valve body** made for rigid PVC-U injection moulding equipped with built-in bores for actuation. ISO 9393 compliant test requisites
- Option of dismounting downstream pipes with the valve in the closed position
- High surface finish stem with double O-Ring and double connection key to the ball, equipped with **visual ball position indicator** for correct handle installation
- **Integrated bracket** for valve anchoring
- Possibility of installing pneumatic and/or electric actuators thanks to the robust anchor tower for easy and quick automation using the **Power Quick module** (optional)
- Possibility to have handle with integrated LSQT limit micro switch, even as a retrofit in existing installations