

# LKDIV - DUAL BLOCK® 3-way ball valve DN 10:50

DUAL BLOCK® 3-way ball valve with metric plain socket ends for solvent welding, L bore.

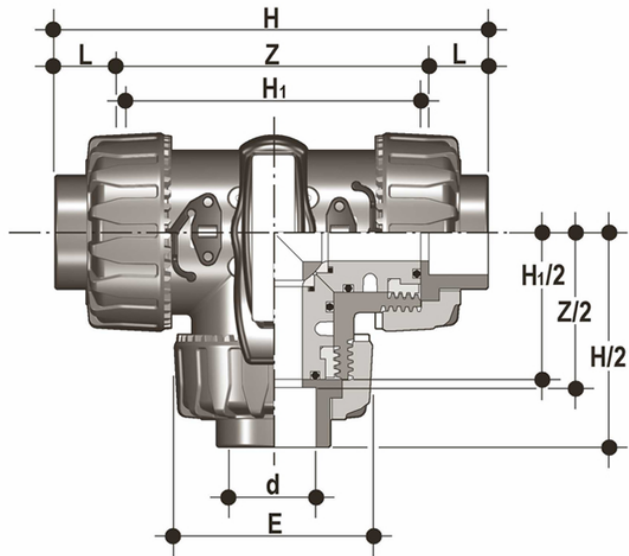

## EPDM

Reference	d	DN	PN	E	H	H <sub>1</sub>	L	Z	g
LKDIV016E	16	10	16	54	118	80	14	90	310
LKDIV020E	20	15	16	54	118	80	16	86	310
LKDIV025E	25	20	16	65	145	100	19	107	550
LKDIV032E	32	25	16	73	160	110	22	116	790
LKDIV040E	40	32	16	86	188.5	131	26	136.5	1275
LKDIV050E	50	40	16	98	219	148	31	157	1660
LKDIV063E	63	50	16	122	266.5	179	38	190.5	2800

## EPDM

Reference	d	DN	PN	E	H	H <sub>1</sub>	L	Z	g
LKDIV016EOLF	16	10	16	54	118	80	14	90	310
LKDIV020EOLF	20	15	16	54	118	80	16	86	310
LKDIV025EOLF	25	20	16	65	145	100	19	107	550
LKDIV032EOLF	32	25	16	73	160	110	22	116	790
LKDIV040EOLF	40	32	16	86	188.5	131	26	136.5	1275
LKDIV050EOLF	50	40	16	98	219	148	31	157	1660
LKDIV063EOLF	63	50	16	122	266.5	179	38	190.5	2800



# LKDIV - DUAL BLOCK® 3-way ball valve DN 10:50

## EPDM

Reference	d	DN	PN	E	H	H <sub>1</sub>	L	Z	g
LKDIV016E0SF	16	10	16	54	118	80	14	90	310
LKDIV020E0SF	20	15	16	54	118	80	16	86	310
LKDIV025E0SF	25	20	16	65	145	100	19	107	550
LKDIV032E0SF	32	25	16	73	160	110	22	116	790
LKDIV040E0SF	40	32	16	86	188.5	131	26	136.5	1275
LKDIV050E0SF	50	40	16	98	219	148	31	157	1660
LKDIV063E0SF	63	50	16	122	266.5	179	38	190.5	2800

## FKM

Reference	d	DN	PN	E	H	H <sub>1</sub>	L	Z	g
LKDIV016F	16	10	16	54	118	80	14	90	310
LKDIV020F	20	15	16	54	118	80	16	86	310
LKDIV025F	25	20	16	65	145	100	19	107	550
LKDIV032F	32	25	16	73	160	110	22	116	790
LKDIV040F	40	32	16	86	188.5	131	26	136.5	1275
LKDIV050F	50	40	16	98	219	148	31	157	1660
LKDIV063F	63	50	16	122	266.5	179	38	190.5	2800

## FKM

Reference	d	DN	PN	E	H	H <sub>1</sub>	L	Z	g
LKDIV016FOLF	16	10	16	54	118	80	14	90	310
LKDIV020FOLF	20	15	16	54	118	80	16	86	310
LKDIV025FOLF	25	20	16	65	145	100	19	107	550
LKDIV032FOLF	32	25	16	73	160	110	22	116	790
LKDIV040FOLF	40	32	16	86	188.5	131	26	136.5	1275
LKDIV050FOLF	50	40	16	98	219	148	31	157	1660
LKDIV063FOLF	63	50	16	122	266.5	179	38	190.5	2800

## FKM

Reference	d	DN	PN	E	H	H <sub>1</sub>	L	Z	g
LKDIV016F0SF	16	10	16	54	118	80	14	90	310
LKDIV020F0SF	20	15	16	54	118	80	16	86	310
LKDIV025F0SF	25	20	16	65	145	100	19	107	550



# LKDIV - DUAL BLOCK® 3-way ball valve DN 10:50

Reference	d	DN	PN	E	H	H <sub>1</sub>	L	Z	g
LKDIV032F0SF	32	25	16	73	160	110	22	116	790
LKDIV040F0SF	40	32	16	86	188.5	131	26	136.5	1275
LKDIV050F0SF	50	40	16	98	219	148	31	157	1660
LKDIV063F0SF	63	50	16	122	266.5	179	38	190.5	2800

# LKDIV - DUAL BLOCK® 3-way ball valve DN 10:50

- Ergonomic HIPVC handle equipped with removable tool to adjust the ball seat carrier. Possibility of installing the **LTKD stroke limiter** (available as an accessory) that permits ball and handle rotation only for set opening and closing angles at 90° or 180°
- **Handle lock 0°- 90° SHKD** (available as an accessory) ergonomically operable during service and padlockable
- **DUAL BLOCK®** patented lock system that ensures union nut tightening hold even in severe conditions such as vibrations or heat dilation
- **Ball shutter** high surface finish with floating type full passage with **T or L port**
- **4 PTFE ball seat system** that compensates axial force guaranteeing optimal manageability and long working life
  
- Connection system for solvent weld, threaded and flanged joints
- Patented **SEAT STOP®** ball carrier system that lets you micro-adjust ball seats and minimise axial force effects
- Easy radial dismounting allowing quick replacement of O-rings and ball seats without any need for tools
- **PN16 True Union valve body** made for rigid PVC-U injection moulding equipped with built-in bores for actuation. ISO 9393 compliant test requisites
- Option of dismounting downstream pipes with the valve in the closed position
- High surface finish stem with double O-Ring and double connection key to the ball, equipped with **visual ball position indicator** for correct handle installation
- **Integrated bracket** for valve anchoring
- Possibility of installing pneumatic and/or electric actuators thanks to the robust anchor tower for easy and quick automation using the **Power Quick module** (optional)
- Possibility to have handle with integrated LSQT limit micro switch, even as a retrofit in existing installations