

VKDBEM - DUAL BLOCK® 2-way ball valve DN 10:50

DUAL BLOCK® 2-way ball valve with PE100 SDR 11 male end connectors for butt welding or electrofusion (CVDE).

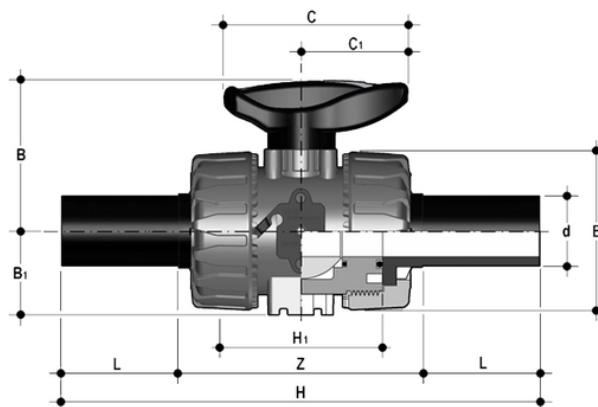

EPDM

Reference	d	DN	PN	B	B ₁	C	C ₁	E	H	H ₁	L	Z	g
VKDBEM020E	20	15	10	54	29	67	40	54	175	65	40,5	94	210
VKDBEM025E	25	20	10	65	34,5	85	49	65	213	70	54	106	325
VKDBEM032E	32	25	10	69,5	39	85	49	73	228	78	56	117	420
VKDBEM040E	40	32	10	82,5	46	108	64	86	247	88	56	131	570
VKDBEM050E	50	40	10	89	52	108	64	98	271	93	60,5	145	900
VKDBEM063E	63	50	10	108	62	134	76	122	300	111	65,5	161	1500

FKM

Reference	d	DN	PN	B	B ₁	C	C ₁	E	H	H ₁	L	Z	g
VKDBEM020F	20	15	10	54	29	67	40	54	175	65	40,5	94	210
VKDBEM025F	25	20	10	65	34,5	85	49	65	213	70	54	106	325
VKDBEM032F	32	25	10	69,5	39	85	49	73	228	78	56	117	420
VKDBEM040F	40	32	10	82,5	46	108	64	86	247	88	56	131	570
VKDBEM050F	50	40	10	89	52	108	64	98	271	93	60,5	145	900
VKDBEM063F	63	50	10	108	62	134	76	122	300	111	65,5	161	1500

VKDBEM - DUAL BLOCK® 2-way ball valve DN 10:50

- Ergonomic HIPVC handle equipped with **removable tool to adjust the ball seat carrier**.
- **Handle lock 0°- 90°** SHKD (available as an accessory) ergonomically operable during service and padlockable
- Robust **integrated bracket for valve anchoring**, for easy and quick automation even after valve installation on the system via the Power Quick module (optional)
- **DUAL BLOCK®** patented lock system that ensures union nut tightening hold even in severe conditions such as vibrations or heat dilation
- Machined high surface finish ball that guarantees a smooth operation and increased reliability

- Connection system for solvent weld, threaded and flanged joints
- Patented **SEAT STOP®** ball carrier system that lets you micro-adjust ball seats and minimise the axial force effect
- Easy radial dismounting allowing quick replacement of O-rings and ball seats without any need for tools
- **PN16 True Union valve body** made for rigid PVC-U injection moulding equipped with built-in bores for actuation. ISO 9393 compliant test requisites
- Option of dismounting downstream pipes with the valve in the closed position
- Floating **full bore ball** with high surface finish
- **Integrated bracket** for valve anchoring
- Ball seat carriers can be adjusted using the **Easytorque adjustment kit**
- Possibility to have handle with integrated LSQT limit micro switch, even as a retrofit in existing installations