

LKDDM - DUAL BLOCK® 3-way ball valve DN 15:50

DUAL BLOCK® 3-way ball valve with male ends for socket welding, metric series, L-port ball.

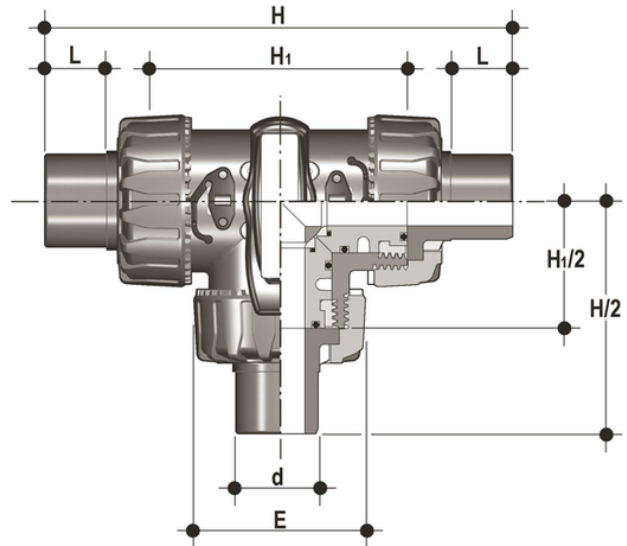

EPDM

Reference	d	DN	PN	E	H	H ₁	L	g
LKDDM020E	20	15	10	54	140	80	16	205
LKDDM025E	25	20	10	65	175	100	18	360
LKDDM032E	32	25	10	73	188	110	20	515
LKDDM040E	40	32	10	86	220	131	22	835
LKDDM050E	50	40	10	98	251	148	23	1100
LKDDM063E	63	50	10	122	294	179	29	1830

FKM

Reference	d	DN	PN	E	H	H ₁	L	g
LKDDM020F	20	15	10	54	140	80	16	205
LKDDM025F	25	20	10	65	175	100	18	360
LKDDM032F	32	25	10	73	188	110	20	515
LKDDM040F	40	32	10	86	220	131	22	835
LKDDM050F	50	40	10	98	251	148	23	1100
LKDDM063F	63	50	10	122	294	179	29	1830

LKDDM - DUAL BLOCK® 3-way ball valve DN 15:50

- Ergonomic HIPVC handle equipped with removable tool to adjust the ball seat carrier. Possibility of installing the **LTKD stroke limiter** (available as an accessory) that permits ball and handle rotation only for set opening and closing angles at 90° or 180°
- **Handle lock 0°- 90° SHKD** (available as an accessory) ergonomically operable during service and padlockable
- **DUAL BLOCK®** patented lock system that ensures union nut tightening hold even in severe conditions such as vibrations or heat dilation
- **Ball shutter** high surface finish with floating type full passage with **T or L port**
- **4 PTFE ball seat system** that compensates axial force guaranteeing optimal manageability and long working life

- Connection system for weld and threaded joints
- Patented **SEAT STOP®** ball seat carrier system that lets you micro-adjust ball seats and minimise axial force effects
- Easy radial disassembly allowing quick replacement of O-rings and ball seats without any need for tools
- PN10 **True Union valve body** made for PP-H injection moulding equipped with built-in bores for actuation. ISO 9393 compliant test requisites
- Option of disassembling downstream pipes with the valve in the closed position
- High surface finish stem with double O-Ring and double groove ball connection, equipped with **optical position indicator** for correct handle installation
- **Integrated bracket** for valve anchoring
- Possibility of installing pneumatic and/or electric actuators thanks to the robust integrated bracket for valve anchoring for easy and quick automation using the Power Quick module (optional)
- Possibility to have handle with integrated LSQT limit micro switch, even as a retrofit in existing installations