

VKDBF - DUAL BLOCK® 2-way ball valve DN 10:50

DUAL BLOCK® 2-way ball valve with long spigot male ends in PVDF for butt welding/ IR (CVDF).

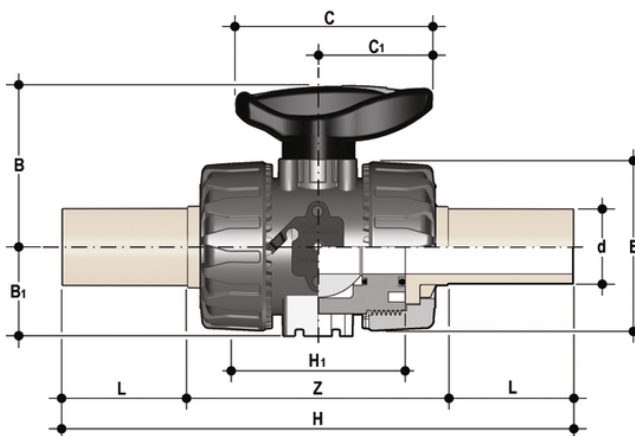

FKM

Reference	d	DN	PN	B	B ₁	C	C ₁	E	H	H ₁	L	Z	g	P
VKDBF020F	20	15	16	54	29	67	40	54	175	65	40,5	94	450	-
VKDBF025F	25	20	16	65	35	85	49	65	212	70	54	106	516	-
VKDBF032F	32	25	16	70	39	85	49	73	226	78	56	117	664	-
VKDBF040F	40	32	16	83	46	108	64	86	246	88	56	131	1020	-
VKDBF050F	50	40	16	89	52	108	64	98	271	93	60,5	145	1350	-
VKDBF063F	63	50	-	108	62	134	76	122	300	111	65,5	161	2330	16

FKM

Reference	d	DN	PN	B	B ₁	C	C ₁	E	H	H ₁	L	Z	g
VKDBF020FOLF	20	15	16	54	29	67	40	54	175	65	40,5	94	450
VKDBF025FOLF	25	20	16	65	35	85	49	65	212	70	54	106	516
VKDBF032FOLF	32	25	16	70	39	85	49	73	226	78	56	117	664
VKDBF040FOLF	40	32	16	83	46	108	64	86	246	88	56	131	1020
VKDBF050FOLF	50	40	16	89	52	108	64	98	271	93	60,5	145	1350
VKDBF063FOLF	63	50	16	108	62	134	76	122	300	111	65,5	161	2330

FKM



VKDBF - DUAL BLOCK® 2-way ball valve DN 10:50

Reference	d	DN	PN	B	B ₁	C	C ₁	E	H	H ₁	L	Z	g
VKDBF020FOSF	20	15	16	54	29	67	40	54	175	65	40,5	94	450
VKDBF025FOSF	25	20	16	65	35	85	49	65	212	70	54	106	516
VKDBF032FOSF	32	25	16	70	39	85	49	73	226	78	56	117	664
VKDBF040FOSF	40	32	16	83	46	108	64	86	246	88	56	131	1020
VKDBF050FOSF	50	40	16	89	52	108	64	98	271	93	60,5	145	1350
VKDBF063FOSF	63	50	16	108	62	134	76	122	300	111	65,5	161	2330

VKDBF – DUAL BLOCK® 2-way ball valve DN 10:50

- Ergonomic HIPVC handle equipped with **removable tool to adjust the ball seat carrier**
- **Handle lock 0°– 90°** SHKD (available as an accessory) ergonomically operable during service and padlockable
- Robust **integrated bracket for valve anchoring**, for easy and quick automation even after valve installation on the system via the Power Quick module (optional)
- **DUAL BLOCK®** patented lock system that ensures union nut tightening hold even in severe conditions such as vibrations or heat dilation
- Machined high surface finish ball that guarantees a smooth operation and increased reliability

- Connection system for solvent weld, threaded and flanged joints
- Patented **SEAT STOP®** ball carrier system that lets you micro-adjust ball seats and minimise the axial force effect
- Easy radial dismounting allowing quick replacement of O-rings and ball seats without any need for tools
- **PN16 True Union valve body** made for rigid PVC-U injection moulding equipped with built-in bores for actuation. ISO 9393 compliant test requisites
- Option of dismounting downstream pipes with the valve in the closed position
- Floating **full bore ball** with high surface finish
- **Integrated bracket** for valve anchoring
- Ball seat carriers can be adjusted using the **Easytorque adjustment kit**
- Possibility to have handle with integrated LSQT limit micro switch, even as a retrofit in existing installations