

VKDDM - DUAL BLOCK® 2-way ball valve DN 10:50

DUAL BLOCK® 2-way ball valve with male ends for socket welding, metric series.

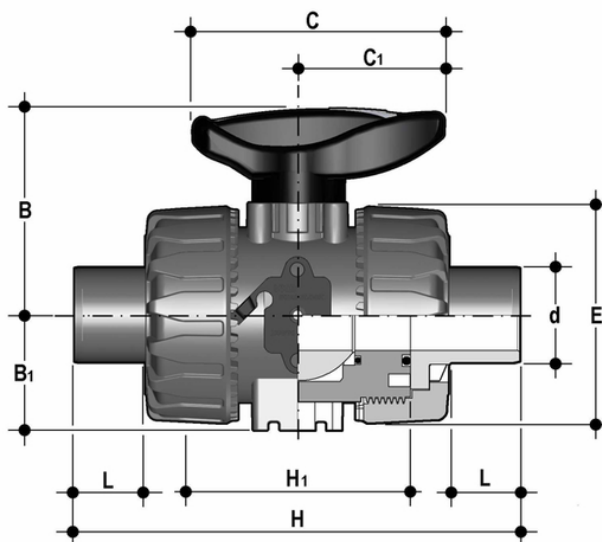

EPDM

Reference	d	DN	PN	B	B ₁	C	C[5:1]	E	H	H ₁	L	g
VKDDM020E	20	15	10	54	29	67	40	54	124	65	16	153
VKDDM025E	25	20	10	65	34,5	85	49	65	144	70	18	222
VKDDM032E	32	25	10	69,5	39	85	49	73	154	78	20	303
VKDDM040E	40	32	10	82,5	46	108	64	86	174	88	22	485
VKDDM050E	50	40	10	89	52	108	64	98	194	93	23	672
VKDDM063E	63	50	10	108	62	134	76	122	224	111	29	1176

FKM

Reference	d	DN	PN	B	B ₁	C	C[5:1]	E	H	H ₁	L	g
VKDDM020F	20	15	10	54	29	67	40	54	124	65	16	153
VKDDM025F	25	20	10	65	34,5	85	49	65	144	70	18	222
VKDDM032F	32	25	10	69,5	39	85	49	73	154	78	20	303
VKDDM040F	40	32	10	82,5	46	108	64	86	174	88	22	485
VKDDM050F	50	40	10	89	52	108	64	98	194	93	23	672
VKDDM063F	63	50	10	108	62	134	76	122	224	111	29	1176

VKDDM – DUAL BLOCK® 2-way ball valve DN 10:50

- Ergonomic HIPVC handle equipped with **removable tool to adjust the ball seat carrier**.
- **Handle lock 0°– 90°** SHKD (available as an accessory) ergonomically operable during service and padlockable
- Robust **integrated bracket for valve anchoring**, for easy and quick automation even after valve installation on the system via the Power Quick module (optional)
- **DUAL BLOCK®** patented lock system that ensures union nut tightening hold even in severe conditions such as vibrations or heat dilation
- Machined high surface finish ball that guarantees a smooth operation and increased reliability

- Connection system for solvent weld, threaded and flanged joints
- Patented **SEAT STOP®** ball carrier system that lets you micro-adjust ball seats and minimise the axial force effect
- Easy radial dismounting allowing quick replacement of O-rings and ball seats without any need for tools
- **PN16 True Union valve body** made for rigid PVC-U injection moulding equipped with built-in bores for actuation. ISO 9393 compliant test requisites
- Option of dismounting downstream pipes with the valve in the closed position
- Floating **full bore ball** with high surface finish
- **Integrated bracket** for valve anchoring
- Ball seat carriers can be adjusted using the **Easytorque adjustment kit**
- Possibility to have handle with integrated LSQT limit micro switch, even as a retrofit in existing installations