

VKDIF/SHX - DUAL BLOCK® 2-way ball valve DN 10:50

DUAL BLOCK® 2-way ball valve with handle lock and STAINLESS steel threaded inserts for fastening, with female ends for butt welding, metric series.

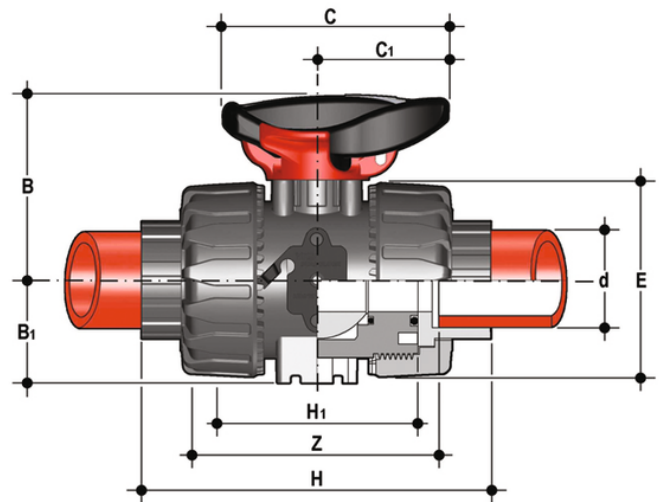

Reference	d	DN	PN	B	B ₁	C	C[5:1]	E	H	H ₁	Z	g
VKDIFSHX016F	16	10	16	54	29	67	40	54	102	65	74,5	291
VKDIFSHX020F	20	15	16	54	29	67	40	54	102	65	73	272
VKDIFSHX025F	25	20	16	65	34,5	85	49	65	114	70	82	445
VKDIFSHX032F	32	25	16	69,5	39	85	49	73	126	78	90	584
VKDIFSHX040F	40	32	16	82,5	46	108	64	86	141	88	100	938
VKDIFSHX050F	50	40	16	89	52	108	64	98	164	93	117	1242
VKDIFSHX063F	63	50	16	108	62	134	76	122	199	111	144	2187

VKDIF/SHX - DUAL BLOCK® 2-way ball valve DN 10:50

- Ergonomic HIPVC handle equipped with **removable tool to adjust the ball seat carrier**
- **Handle lock 0°- 90° SHKD** (available as an accessory) ergonomically operable during service and padlockable
- Robust **integrated bracket for valve anchoring**, for easy and quick automation even after valve installation on the system via the Power Quick module (optional)
- **DUAL BLOCK®** patented lock system that ensures union nut tightening hold even in severe conditions such as vibrations or heat dilation
- Machined high surface finish ball that guarantees a smooth operation and increased reliability

- Connection system for solvent weld, threaded and flanged joints
- Patented **SEAT STOP®** ball carrier system that lets you micro-adjust ball seats and minimise the axial force effect
- Easy radial dismounting allowing quick replacement of O-rings and ball seats without any need for tools
- **PN16 True Union valve body** made for rigid PVC-U injection moulding equipped with built-in bores for actuation. ISO 9393 compliant test requisites
- Option of dismounting downstream pipes with the valve in the closed position
- Floating **full bore ball** with high surface finish
- **Integrated bracket** for valve anchoring
- Ball seat carriers can be adjusted using the **Easytorque adjustment kit**
- Possibility to have handle with integrated LSQT limit micro switch, even as a retrofit in existing installations