

VKRBEM – DUAL BLOCK® regulating ball valve DN 10:50

DUAL BLOCK® regulating ball valve with PE100 SDR 11 male end connectors for butt welding or electrofusion (CVDE).

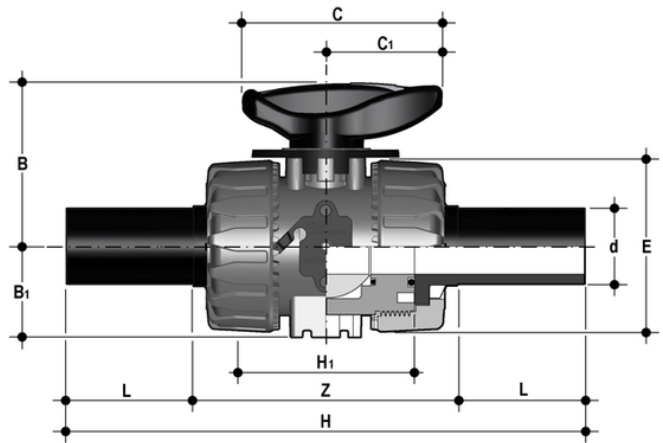

EPDM

Reference	d	DN	PN	B	B ₁	C	C[5:1]	E	H	H ₁	L	Z	g
VKRBEM020E	20	15	10	54	29	67	40	54	175	65	40,5	94	210
VKRBEM025E	25	20	10	65	34,5	85	49	65	213	70	54	106	325
VKRBEM032E	32	25	10	69,5	39	85	49	73	228	78	56	117	420
VKRBEM040E	40	32	10	82,5	46	108	64	86	247	88	56	131	570
VKRBEM050E	50	40	10	89	52	108	64	98	271	93	60,5	145	900
VKRBEM063E	63	50	10	108	62	134	76	122	300	111	65,5	161	1500

FKM

Reference	d	DN	PN	B	B ₁	C	C[5:1]	E	H	H ₁	L	Z	g
VKRBEM020F	20	15	10	54	29	67	40	54	175	65	40,5	94	210
VKRBEM025F	25	20	10	65	34,5	85	49	65	213	70	54	106	325
VKRBEM032F	32	25	10	69,5	39	85	49	73	228	78	56	117	420
VKRBEM040F	40	32	10	82,5	46	108	64	86	247	88	56	131	570
VKRBEM050F	50	40	10	89	52	108	64	98	271	93	60,5	145	900
VKRBEM063F	63	50	10	108	62	134	76	122	300	111	65,5	161	1500

VKRBEM – DUAL BLOCK®

regulating ball valve DN 10:50

- HIPVC ergonomic multifunctional handle with **position indicator** and tool to adjust the ball seat carrier
- Flow direction and opening angle indication plate with **graduated scale with 5° detail** for clear and accurate readings
- 90° operating angle that permits **the use of standard** quarter turn **actuators**
- The patented ball design provides **linear flow adjustment** throughout its range of operation even when the valve is open just a few degrees and guarantees minimum pressure drops
- Patented **DUAL BLOCK®** system: prevents union nuts from loosening even under extreme operating conditions: e.g. vibration or thermal expansion

- Connection system for solvent weld, threaded and flanged joints
- Patented **SEAT STOP®** ball carrier system that lets you micro-adjust seals and minimise the axial force effect
- Easy radial dismounting allowing quick replacement of O-rings and ball seats without any need for tools
- **PN16 True Union valve body** made for rigid PVC-U injection moulding equipped with built-in bores for actuation. ISO 9393 compliant test requisites
- Option of dismounting downstream pipes with the valve in the closed position
- High surface finish stem with double O-Ring and double connection key to ball
- **Integrated bracket** for valve anchoring
- Ball seat carrier can be adjusted using the **Easytorque adjustment kit**
- Actuation option: version with electric modulating actuator with 4-20 mA / 0-10 V inlet and 4-20 mA / 0-10 V outlet to monitor the position
- Valve suitable for carrying fluids that are clean and free of suspended particles