

VKROM - DUAL BLOCK® regulating ball valve DN 10:50

DUAL BLOCK® regulating ball valve with EN/ISO/DIN fixed flange, drilled PN10/16. Face to face according to EN 558-1.

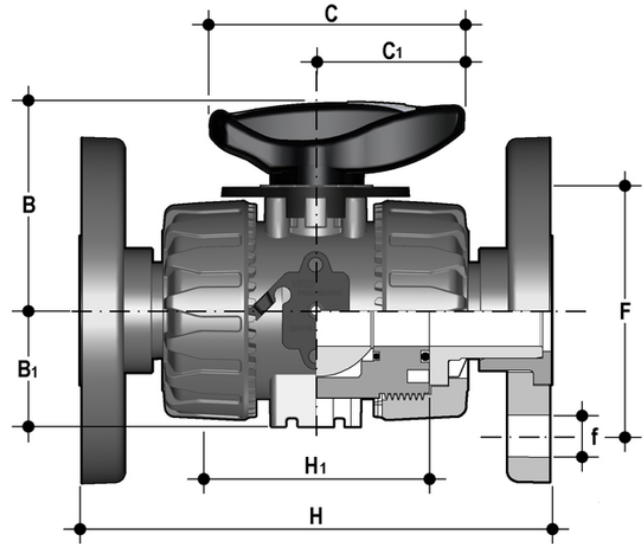

EPDM

Reference	d	DN	PN	B	B ₁	C	C[5:1]	F	f	H	H1	U	Sp	g
VKROM020E	20	15	10	54	29	67	40	65	14	130	65	4	11	387
VKROM025E	25	20	10	65	34,5	85	49	75	14	150	70	4	14	504
VKROM032E	32	25	10	69,5	39	85	49	85	14	160	78	4	14	697
VKROM040E	40	32	10	82,5	46	108	64	100	18	180	88	4	14	1075
VKROM050E	50	40	10	89	52	108	64	110	18	200	93	4	16	1346
VKROM063E	63	50	10	108	62	134	76	125	18	230	111	4	16	2060

FKM

Reference	d	DN	PN	B	B ₁	C	C[5:1]	F	f	H	H1	U	Sp	g
VKROM020F	20	15	10	54	29	67	40	65	14	130	65	4	11	387
VKROM025F	25	20	10	65	34,5	85	49	75	14	150	70	4	14	504
VKROM032F	32	25	10	69,5	39	85	49	85	14	160	78	4	14	697
VKROM040F	40	32	10	82,5	46	108	64	100	18	180	88	4	14	1075
VKROM050F	50	40	10	89	52	108	64	110	18	200	93	4	16	1346
VKROM063F	63	50	10	108	62	134	76	125	18	230	111	4	16	2060

VKROM – DUAL BLOCK®

regulating ball valve DN 10:50

- HIPVC ergonomic multifunctional handle with **position indicator** and tool to adjust the ball seat carrier
- Flow direction and opening angle indication plate with **graduated scale with 5° detail** for clear and accurate readings
- 90° operating angle that permits **the use of standard** quarter turn **actuators**
- The patented ball design provides **linear flow adjustment** throughout its range of operation even when the valve is open just a few degrees and guarantees minimum pressure drops
- Patented **DUAL BLOCK®** system: prevents union nuts from loosening even under extreme operating conditions: e.g. vibration or thermal expansion

- Connection system for solvent weld, threaded and flanged joints
- Patented **SEAT STOP®** ball carrier system that lets you micro-adjust seals and minimise the axial force effect
- Easy radial dismounting allowing quick replacement of O-rings and ball seats without any need for tools
- **PN16 True Union valve body** made for rigid PVC-U injection moulding equipped with built-in bores for actuation. ISO 9393 compliant test requisites
- Option of dismounting downstream pipes with the valve in the closed position
- High surface finish stem with double O-Ring and double connection key to ball
- **Integrated bracket** for valve anchoring
- Ball seat carrier can be adjusted using the **Easytorque adjustment kit**
- Actuation option: version with electric modulating actuator with 4-20 mA / 0-10 V inlet and 4-20 mA / 0-10 V outlet to monitor the position
- Valve suitable for carrying fluids that are clean and free of suspended particles