

VKRDM - DUAL BLOCK® regulating ball valve DN 10:50

DUAL BLOCK® regulating ball valve with male ends for socket welding, metric series.

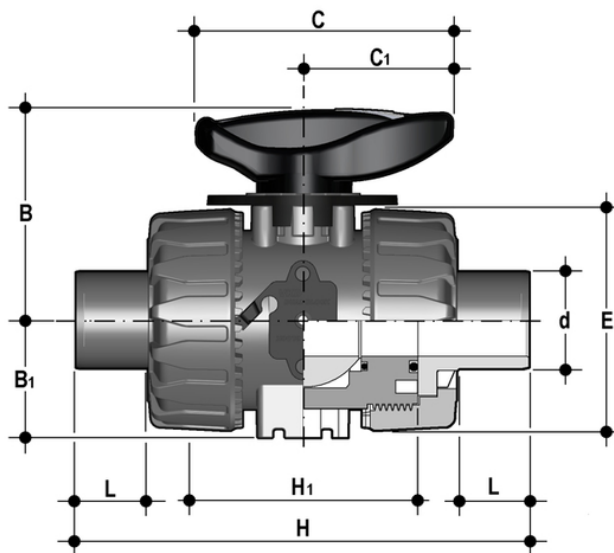

EPDM

Reference	d	DN	PN	B	B ₁	C	C ₁	E	H	H ₁	L	g
VKRDM020E	20	15	10	54	29	67	40	54	144	70	18	222
VKRDM025E	25	20	10	65	34,5	85	49	65	154	78	20	303
VKRDM032E	32	25	10	69,5	39	85	49	73	174	88	22	485
VKRDM040E	40	32	10	82,5	46	108	64	86	194	93	23	672
VKRDM050E	50	40	10	89	52	108	64	98	224	111	29	1176
VKRDM063E	63	50	10	108	62	134	76	122	224	111	38	1607

FKM

Reference	d	DN	PN	B	B ₁	C	C ₁	E	H	H ₁	L	g
VKRDM020F	20	15	10	54	29	67	40	54	144	70	18	222
VKRDM025F	25	20	10	65	34,5	85	49	65	154	78	20	303
VKRDM032F	32	25	10	69,5	39	85	49	73	174	88	22	485
VKRDM040F	40	32	10	82,5	46	108	64	86	194	93	23	672
VKRDM050F	50	40	10	89	52	108	64	98	224	111	29	1176
VKRDM063F	63	50	10	108	62	134	76	122	224	111	38	1607

VKRDM – DUAL BLOCK®

regulating ball valve DN 10:50

- HIPVC ergonomic multifunctional handle with **position indicator** and tool to adjust the ball seat carrier
- Flow direction and opening angle indication plate with **graduated scale with 5° detail** for clear and accurate readings
- 90° operating angle that permits **the use of standard** quarter turn **actuators**
- The patented ball design provides **linear flow adjustment** throughout its range of operation even when the valve is open just a few degrees and guarantees minimum pressure drops
- Patented **DUAL BLOCK®** system: prevents union nuts from loosening even under extreme operating conditions: e.g. vibration or thermal expansion

- Connection system for solvent weld, threaded and flanged joints
- Patented **SEAT STOP®** ball carrier system that lets you micro-adjust seals and minimise the axial force effect
- Easy radial dismounting allowing quick replacement of O-rings and ball seats without any need for tools
- **PN16 True Union valve body** made for rigid PVC-U injection moulding equipped with built-in bores for actuation. ISO 9393 compliant test requisites
- Option of dismounting downstream pipes with the valve in the closed position
- High surface finish stem with double O-Ring and double connection key to ball
- **Integrated bracket** for valve anchoring
- Ball seat carrier can be adjusted using the **Easytorque adjustment kit**
- Actuation option: version with electric modulating actuator with 4-20 mA / 0-10 V inlet and 4-20 mA / 0-10 V outlet to monitor the position
- Valve suitable for carrying fluids that are clean and free of suspended particles