

# SRIF – Ball check valve DN 15:50

Ball check valve with ends for socket welding, metric series.

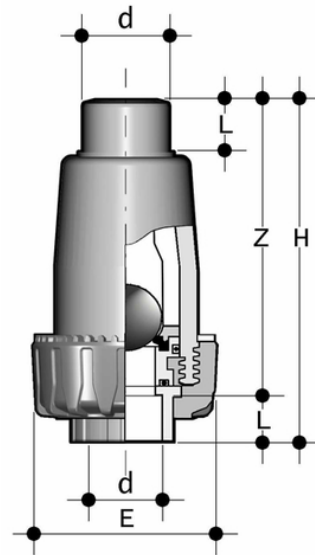

| Reference | d  | DN | PN | E   | H   | L  | Z   | g    |
|-----------|----|----|----|-----|-----|----|-----|------|
| SRIF020F  | 20 | 15 | 16 | 54  | 104 | 16 | 88  | 150  |
| SRIF025F  | 25 | 20 | 16 | 65  | 125 | 19 | 106 | 260  |
| SRIF032F  | 32 | 25 | 16 | 74  | 148 | 22 | 126 | 390  |
| SRIF040F  | 40 | 32 | 16 | 86  | 171 | 26 | 145 | 600  |
| SRIF050F  | 50 | 40 | 16 | 98  | 189 | 31 | 158 | 820  |
| SRIF063F  | 63 | 50 | 16 | 119 | 222 | 38 | 184 | 1420 |



## SRIF – Ball check valve DN 15:50

- Connection system for weld joints
- PN10 **valve body made for PP-H injection moulding** and European Directive 2014/68/EU (PED) compliant for pressurised equipment. ISO 9393 compliant test requirements
- The valve can only be used with fluids with specific weight under 1,20 g/cm<sup>3</sup>
- **Sealing system with antiblow out design**
- Ball entirely in talc-filled PP
- Can be maintained with the valve body installed
- Can be **installed** in either a **vertical** (preferable) or **horizontal position**