

PHONOAIR PLUS sound-proof air kit

Included in the package:

- 2 pcs. grids Ø160 with mesh (inspectable)
- Protective cover
- Extension pipe not included

Advantages:

- Compact (10,8 LT)
- Reinforced box
- No maintenance

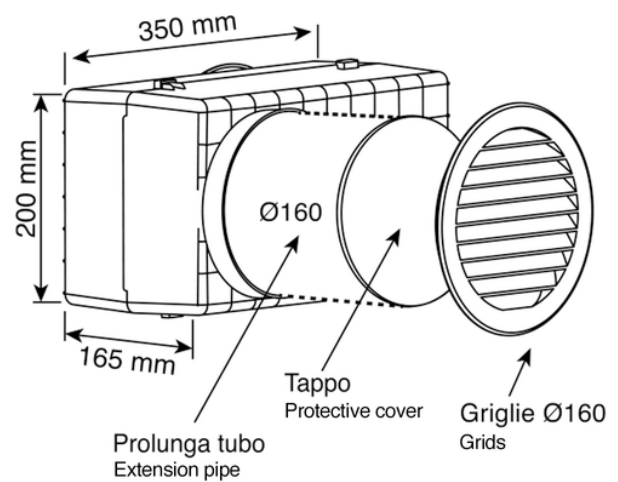
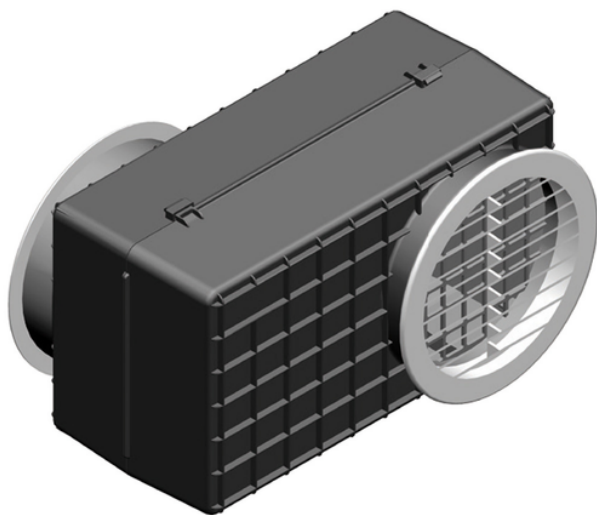

Reference	Colour	Dim (mm)
1PA1608	Black	250 x 200 x 165