

SUPER PLUS, activated sludge system

One-piece polyethylene packaged

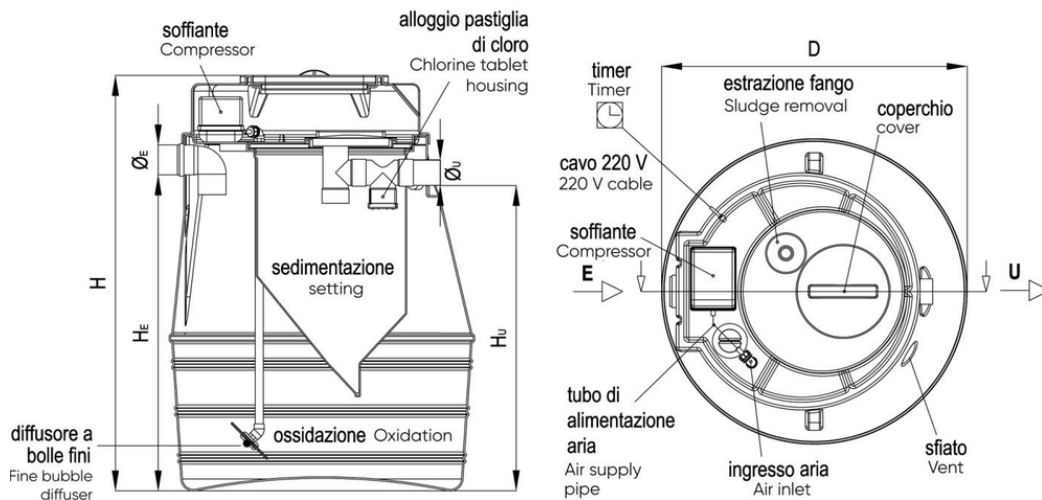
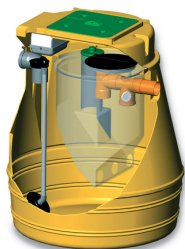

| Reference | D (cm) | Height H (cm) | HE (cm) | HU (cm) | V _{ox} (m ³) | V _{sett} (m ³) | ØE e ØU (mm) | Power (Kw) | Item | Users (E.I.) |
|-----------|--------|---------------|---------|---------|-----------------------------------|-------------------------------------|--------------|------------|----------------|--------------|
| ISO9220 | 120 | 142 | 105 | 100 | 0,73 | 0,17 | 100 | 30 (W) | SUPER PLUS S.1 | 5 |
| ISO9221 | 120 | 162 | 125 | 120 | 1,14 | 0,25 | 100 | 40 (W) | SUPER PLUS S.2 | 10 |
| ISO9222 | 120 | 202 | 165 | 160 | 1,44 | 0,5 | 125 | 40 (W) | SUPER PLUS S.3 | 15 |
| ISO9223 | 160 | 187 | 140 | 135 | 2,47 | 0,5 | 140 | 45 (W) | SUPER PLUS S.4 | 20 |
| ISO9224 | 160 | 222 | 175 | 170 | 3,47 | 0,6 | 140 | 50 (W) | SUPER PLUS S.5 | 25 |