

TRDE SDR17 - 90° reduced tee

90° reduced tee, long spigot for butt welding SDR 17 - S8.

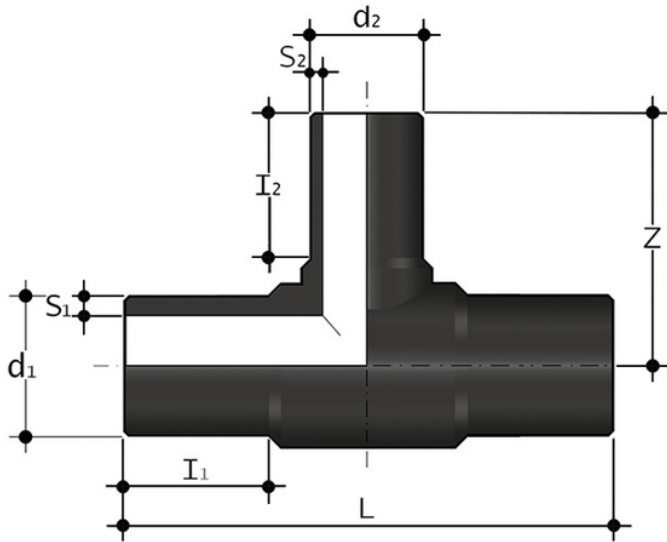

Reference	d_1	d_2	L	Z	h_1	h_2	S_1	S_2	g
TRDE17063050	*63	50	213	100	63	56	3,8	3,0	227
TRDE17075050	*75	50	253	113	70	55	4,5	3,0	400
TRDE17075063	*75	63	252	116	69	62	4,5	3,8	450
TRDE17090050	*90	50	278	118	80	59	5,4	3,0	600
TRDE17090063	*90	63	272	139	81	65	5,4	3,8	610
TRDE17090075	*90	75	272	139	74	71	5,4	4,5	681
TRDE17110063	*110	63	320	147	88	67	6,6	3,8	1010
TRDE17110075	*110	75	315	152	84	70	6,6	4,5	880
TRDE17110090	*110	90	318	160	86	81	6,6	5,4	1055
TRDE17125063	*125	63	366	157	101	70	7,4	3,8	1420
TRDE17125110	*125	110	334	168	84	83	7,4	6,6	1320
TRDE17160063	*160	63	411	172	103	65	9,5	3,8	2525
TRDE17160075	*160	75	343	180	98	74	9,5	4,5	2640
TRDE17160090	*160	90	412	190	104	82	9,5	5,4	2610
TRDE17180090	*180	90	484	200	110	82	10,7	5,4	2780
TRDE17180110	*180	110	486	205	110	86	10,7	6,6	4320
TRDE17180160	*180	160	411	205	105	94	10,7	9,5	3540
TRDE17200063	*200	63	550	225	134	80	11,9	3,8	5220
TRDE17200090	*200	90	504	216	125	82	11,9	5,4	5015
TRDE17200110	*200	110	506	219	124	85	11,9	6,6	5155

TRDE SDR17 - 90° reduced tee

Reference	d ₁	d ₂	L	Z	h ₁	h ₂	S ₁	S ₂	g
TRDE17200160	*200	160	500	235	120	101	11,9	9,5	5430
TRDE17225075	*225	75	440	226	120	75	13,4	4,5	4980
TRDE17225090	*225	90	555	226	129	82	13,4	5,4	7010
TRDE17225110	*225	110	556	236	130	86	13,4	6,6	7150
TRDE17225160	*225	160	555	255	128	107	13,4	9,5	7220
TRDE17225180	*225	180	558	284	128	107	13,4	10,7	7795
TRDE17250110	*250	110	580	242	133	85	14,8	6,6	8095
TRDE17250200	*250	200	625	290	148	116	14,8	11,9	11060
TRDE17315110	*315	110	699	277	155	84	18,7	6,6	15860
TRDE17315160	*315	160	695	300	153	102	18,7	9,5	15585
TRDE17315200	*315	200	690	313	155	117	18,7	11,9	17910
TRDE17315225	*315	225	690	320	155	125	18,7	13,4	16040
TRDE17315250	*315	250	695	329	154	135	18,7	14,8	16600

TRDE SDR17 – 90° reduced tee

- Size range: d 12 ÷ d 800 (mm)
- Nominal pressure: SDR 17 (PN10) with water at 20 °C, SDR 11 (PN16) with water at 20 °C
- Temperature range: -40 °C ÷ 60 °C
- Coupling standards – Reference standards:
 - Welding: EN ISO 15494. Can be coupled to pipes according to EN ISO 15494
 - Flanging system: ISO 7005-1, EN 1092-1, EN ISO 15494, ANSI B16.5 cl.150
 - Construction criteria: UNI EN ISO 15494
 - Test methods and requirements: UNI EN ISO 15494
 - Installation criteria: DVS 2202-1, DVS 2207-1, UNI EN 12201- 3, UNI 10520, ISO 21307, UNI 10521, UNI EN 1555-3, ISO 4427- 3, ISO 4437-3
- Fitting material: PE-HD
- Seal material: EPDM, FKM