

# GDE SDR11 – 90° elbow

90° elbow, long spigot for butt welding SDR 11 – S 5.

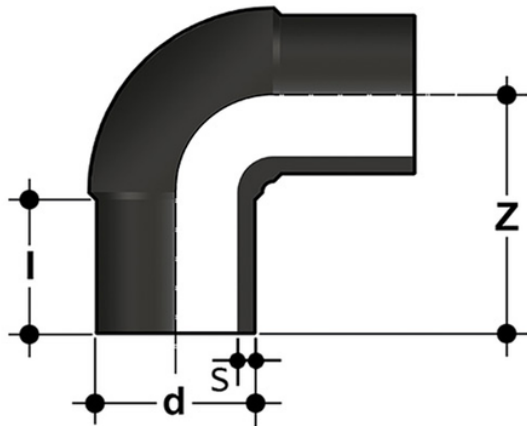

Reference	d	Z	l	S	g
GDE11020	*20	73	52	1,9	21
GDE11025	*25	80	56	2,3	34
GDE11032	*32	79	48	2,9	65
GDE11040	*40	92	52	3,7	97
GDE11050	*50	107	59	4,6	153
GDE11063	*63	131	69	5,8	265
GDE11075	*75	153	76	6,8	415
GDE11090	*90	173	83	8,2	645
GDE11110	*110	195	84	10,0	1070
GDE11125	*125	216	92	11,4	1500
GDE11140	*140	237	96	12,7	2275
GDE11160	*160	262	103	14,6	3364
GDE11180	*180	294	115	16,4	4440
GDE11200	*200	317	122	18,2	6075
GDE11225	*225	351	131	20,5	8030
GDE11250	*250	382	133	22,7	10560
GDE11280	*280	432	153	25,4	15030
GDE11315	*315	471	154	28,6	21360

## GDE SDR11 – 90° elbow

- Size range: d 12 ÷ d 800 (mm)
- Nominal pressure: SDR 17 (PN10) with water at 20 °C, SDR 11 (PN16) with water at 20 °C
- Temperature range: -40 °C ÷ 60 °C
- Coupling standards – Reference standards:
  - Welding: EN ISO 15494. Can be coupled to pipes according to EN ISO 15494
  - Flanging system: ISO 7005-1, EN 1092-1, EN ISO 15494, ANSI B16.5 cl.150
  - Construction criteria: UNI EN ISO 15494
  - Test methods and requirements: UNI EN ISO 15494
  - Installation criteria: DVS 2202-1, DVS 2207-1, UNI EN 12201- 3, UNI 10520, ISO 21307, UNI 10521, UNI EN 1555-3, ISO 4427- 3, ISO 4437-3
- Fitting material: PE-HD
- Seal material: EPDM, FKM