

GBE/GKE SDR11 - 90° Bend

90° bend, short spigot for butt welding SDR 11 - S 5.

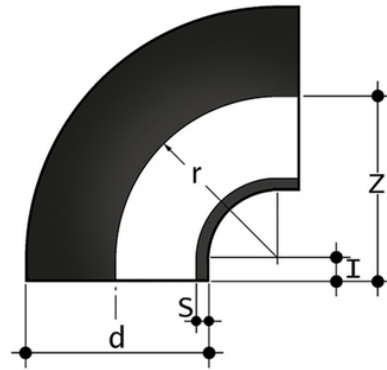

Reference	d	Z	l	r	S	g
GKE11020	20	34	20	18	1,9	7
GKE11025	25	37	20	18	2,3	12
GKE11032	32	40	21	20	2,9	20
GKE11040	40	51	22	35	3,7	40
GKE11050	50	62	23	36	4,6	74
GKE11063	63	77	21	65	5,8	148
GKE11075	75	85	21	75	6,8	212
GKE11090	90	100	22	90	8,2	361
GKE11110	110	120	25	110	10,0	635
GBE11125	125	140	15	125	11,4	1007
GBE11140	140	155	15	140	12,7	1391
GBE11160	160	175	15	160	14,6	1980
GBE11180	*180	184	15	180	16,4	2585
GBE11200	200	215	15	200	18,2	3885
GBE11225	225	245	20	225	20,5	5655
GBE11250	250	275	25	250	22,7	7652
GBE11280	280	310	30	280	25,4	10663
GBE11315	315	350	35	315	28,6	15279
GBE11355	*355	380	38	355	32,2	20825
GBE11400	*400	434	41	400	36,3	30214



GBE/GKE SDR11 - 90° Bend

Reference	d	Z	l	r	S	g
GBE11450	*450	510	60	450	40,9	55482
GBE11500	*500	560	60	500	45,4	71250



GBE/GKE SDR11 - 90° Bend

- Size range: d 12 ÷ d 800 (mm)
- Nominal pressure: SDR 17 (PN10) with water at 20 °C, SDR 11 (PN16) with water at 20 °C
- Temperature range: -40 °C ÷ 60 °C
- Coupling standards - Reference standards:
 - Welding: EN ISO 15494. Can be coupled to pipes according to EN ISO 15494
 - Flanging system: ISO 7005-1, EN 1092-1, EN ISO 15494, ANSI B16.5 cl.150
 - Construction criteria: UNI EN ISO 15494
 - Test methods and requirements: UNI EN ISO 15494
 - Installation criteria: DVS 2202-1, DVS 2207-1, UNI EN 12201- 3, UNI 10520, ISO 21307, UNI 10521, UNI EN 1555-3, ISO 4427- 3, ISO 4437-3
- Fitting material: PE-HD
- Seal material: EPDM, FKM