

# SUPER PLUS MIX, activated sludge system

Delivery includes:

compressor, timer, activation enzymes, and chlorine disinfection tablet.

Compliance with standard:

- 2006/42/CE
- 2004/108/CE
- 2006/95/CE

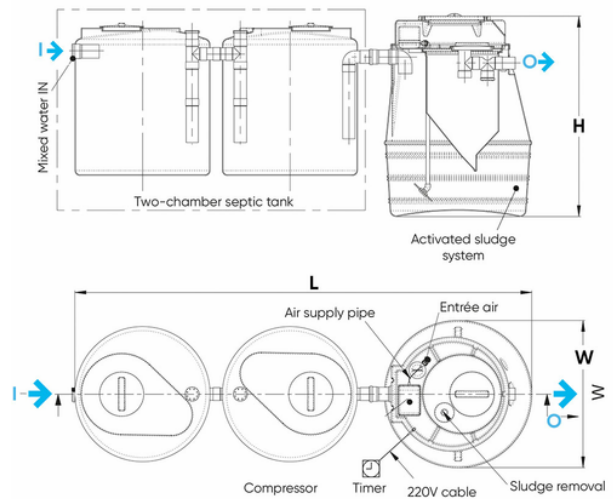

Reference	Height H (cm)	L (cm)	Item	Users (E.I.)	Super	Anaerobic Percolator Filter
IS09400	H= 142 / W= 120	340	S.M.1	5	Super Plus S.1	Type 400
IS09401	H= 142 / W= 120	340	S.M.2	10	Super Plus S.1	Type 800
IS09402	H= 162 / W= 120	420	S.M.3	15	Super Plus S.2	Type 1000
IS09403	H= 202 / W= 120	420	S.M.4	20	Super Plus S.3	Type 1500
IS09405	H= 142 / W= 120	340	S.M.1	5	Super Plus S.1	Type 400
IS09404	H= 222 / W= 160	520	S.M.6	30	Super Plus S.5	Type 3000