

# GBE SDR33 - 90° Bend

90° bend, short spigot for butt welding PN5 code SDR 33 - S 16.

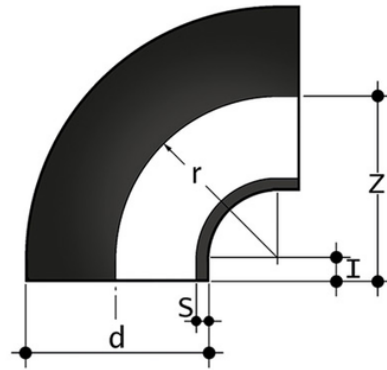

Reference	d	Z	l	r	S	g
GBE33110	*110	138	28	110	3,4	215
GBE33450	*450	450	50	400	13,8	15000
GBE33400	*400	434	41	400	12,3	11040
GBE33355	*355	380	15	355	10,9	8900
GBE33315	*315	322	22	315	9,7	5020
GBE33280	*280	290	24	280	8,6	4380
GBE33250	*250	255	20	250	7,7	2439
GBE33225	*225	236	21	225	6,9	1944
GBE33200	*200	206	19	200	6,2	1740
GBE33180	*180	200	8	180	5,5	1220
GBE33160	*160	200	40	160	4,9	745
GBE33140	*140	175	35	140	4,3	460
GBE33125	*125	130	15	125	3,9	352
GBE33500	*500	450	50	400	15,3	18480

# GBE SDR33 – 90° Bend

- Size range: d 12 ÷ d 800 (mm)
- Nominal pressure: SDR 17 (PN10) with water at 20 °C, SDR 11 (PN16) with water at 20 °C
- Temperature range: -40 °C ÷ 60 °C
- Coupling standards – Reference standards:
  - Welding: EN ISO 15494. Can be coupled to pipes according to EN ISO 15494
  - Flanging system: ISO 7005-1, EN 1092-1, EN ISO 15494, ANSI B16.5 cl.150
  - Construction criteria: UNI EN ISO 15494
  - Test methods and requirements: UNI EN ISO 15494
  - Installation criteria: DVS 2202-1, DVS 2207-1, UNI EN 12201- 3, UNI 10520, ISO 21307, UNI 10521, UNI EN 1555-3, ISO 4427- 3, ISO 4437-3
- Fitting material: PE-HD
- Seal material: EPDM, FKM