

VMDA - DIAPHRAGM VALVE

Diaphragm valve with male ends for solvent welding, metric series.

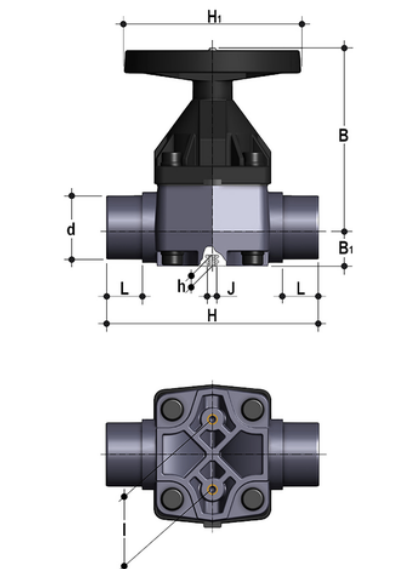

EPDM

Reference	d	DN	PN	B	B ₁	H	H ₁	h	l	J	L	g
VMDA090E	90	80	*10	225	55	300	200	23	100	M12	51	7290
VMDA110E	110	100	*10	295	69	340	250	23	120	M12	61	10900

FKM

Reference	d	DN	PN	B	B ₁	H	H ₁	h	l	J	L	g
VMDA090F	90	80	*10	225	55	300	200	23	100	M12	51	7290
VMDA110F	110	100	*10	295	69	340	250	23	120	M12	61	10900

PTFE

Reference	d	DN	PN	B	B ₁	H	H ₁	h	l	J	L	g
VMDA090P	90	80	*10	225	55	300	200	23	100	M12	51	7290
VMDA110P	110	100	*10	295	69	340	250	23	120	M12	61	10900

VMDA - DIAPHRAGM VALVE

- **Handwheel** in (PA-GR) with high mechanical strength and ergonomic **grip for optimum manageability**
- **Metal optical position indicator** supplied as standard
- **Full protection bonnet in PP-GR** Internal circular and symmetrical diaphragm sealing area
- Diaphragm available in EPDM, FPM, PTFE (NBR on request) and easy to replace
- **Threaded metal inserts** for anchoring the valve
- **New valve body internal design:** substantially higher flow coefficient resulting in lower pressure drops. Optimised adjustment curve for effective and precise flow rate regulation

- Connection system for solvent welding and for flanged joints
- **Optimised fluid dynamic design:** maximum output flow rate thanks to the optimised efficiency of the fluid dynamics that characterise the new internal geometry of the body
- Handwheel that stays at the same height during rotation, with internal bearing to minimise friction and operating torque
- Standard optical indicator
- **Internal operating components in metal** totally isolated from the conveyed fluid
- Bonnet fastening screws in STAINLESS steel protected against the external environment by PE plugs
- **New flanged bodies:** the new bodies, characterised by a monolithic flanged structure, are available in PVC-U, PVC-C, PP-H and PVDF. This design, free from body and flange joints, greatly reduces mechanical stress and increases system performance.