

TKDIA - DUAL BLOCK® 3-WAY BALL VALVE

DUAL BLOCK® 3-way ball valve with metric plain socket ends for solvent welding, T bore.

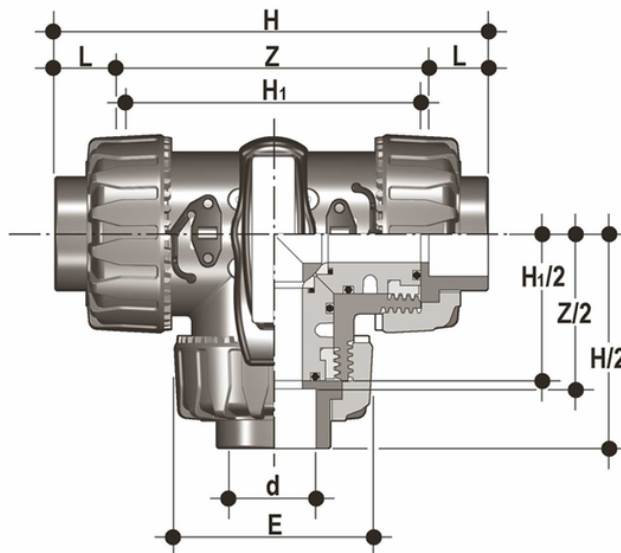

EPDM

Reference	d	DN	PN	E	H	H ₁	L	Z	g
TKDIA020E	20	15	16	54	118	80	16	86	310
TKDIA025E	25	20	16	65	145	100	19	107	550
TKDIA032E	32	25	16	73	160	110	22	116	790
TKDIA040E	40	32	16	86	188.5	131	26	136.5	1275
TKDIA050E	50	40	16	98	219	148	31	157	1660
TKDIA063E	63	50	16	122	266.5	179	38	190.5	2800

FKM

Reference	d	DN	PN	E	H	H ₁	L	Z	g
TKDIA020F	20	15	16	54	118	80	16	86	310
TKDIA025F	25	20	16	65	145	100	19	107	550
TKDIA032F	32	25	16	73	160	110	22	116	790
TKDIA040F	40	32	16	86	188.5	131	26	136.5	1275
TKDIA050F	50	40	16	98	219	148	31	157	1660
TKDIA063F	63	50	16	122	266.5	179	38	190.5	2800

TKDIA - DUAL BLOCK® 3-WAY BALL VALVE

- Ergonomic HIPVC handle equipped with removable tool to adjust the ball seat carrier. Possibility of installing the **LTKD stroke limiter** (available as an accessory) that permits ball and handle rotation only for set opening and closing angles at 90° or 180°
- **Handle lock 0°- 90° SHKD** (available as an accessory) ergonomically operable during service and padlockable
- **DUAL BLOCK®** patented lock system that ensures union nut tightening hold even in severe conditions such as vibrations or heat dilation
- **Ball shutter** high surface finish with floating type full passage with **T or L port**
- **4 PTFE ball seat system** that compensates axial force guaranteeing optimal manageability and long working life

- Connection system for solvent weld, threaded and flanged joints
- Patented **SEAT STOP®** ball carrier system that lets you micro-adjust ball seats and minimise axial force effects
- Easy radial dismounting allowing quick replacement of O-rings and ball seats without any need for tools
- **PN16 True Union valve body** made for rigid PVC-U injection moulding equipped with built-in bores for actuation. ISO 9393 compliant test requisites
- Option of dismounting downstream pipes with the valve in the closed position
- High surface finish stem with double O-Ring and double connection key to the ball, equipped with **visual ball position indicator** for correct handle installation
- **Integrated bracket** for valve anchoring
- Possibility of installing pneumatic and/or electric actuators thanks to the robust anchor tower for easy and quick automation using the **Power Quick module** (optional)
- Possibility to have handle with integrated LSQT limit micro switch, even as a retrofit in existing installations